

green

IEEE

BOOK™



142™

IEEE Recommended Practice for

**Grounding of
Industrial and
Commercial Power
Systems**

Published by the
Institute of Electrical and
Electronics Engineers, Inc.

IEEE Std 142™-2007
(Revision of
IEEE Std 142-1991)

IEEE Std 142™-2007

(Revision of
IEEE Std 142-1991)

IEEE Recommended Practice for Grounding of Industrial and Commercial Power Systems

Sponsor

**Power Systems Engineering Committee
of the
IEEE Industry Applications Society**

Approved 7 June 2007

IEEE-SA Standards Board

Contents

Chapter 1

System grounding	1
1.1 Introduction.....	1
1.2 Definitions.....	2
1.3 Purposes of system grounding	4
1.4 Methods of system neutral grounding.....	5
1.5 Obtaining the system neutral	22
1.6 Location of system grounding points.....	28
1.7 Grounding of industrial and commercial generators	38
1.8 Autotransformers	48
1.9 System grounding for uninterruptible power systems	53
1.10 Portable mining equipment supply systems.....	57
1.11 Creation of stray currents and potentials	60
1.12 Avoiding common-mode noise.....	62
1.13 Limiting transferred earth potentials.....	63
1.14 “Resonantly” produced voltages.....	64
1.15 Grounding of dc power systems	66
1.16 Normative references	70
1.17 Bibliography	73

Chapter 2

Equipment grounding.....	75
2.1 Basic objectives	75
2.2 Fundamental concepts.....	77
2.3 Equipment grounding as influenced by type of use.....	95
2.4 Outdoor open-frame substations	95
2.5 Unit substations.....	99
2.6 Installations serving heavy portable electric machinery	100
2.7 Interior wiring systems	104
2.8 Interior unit substations and switching centers.....	110
2.9 Utilization equipment.....	111
2.10 Normative references	114
2.11 Bibliography	116

Chapter 3

Static and lightning protection grounding.....	119
3.1 Introduction.....	119
3.2 Static grounding.....	119
3.3 Lightning protection grounding	140
3.4 Normative references	156
3.5 Bibliography	159

Chapter 4	
Connection to earth	161
4.1 Resistance to earth	161
4.2 Ground electrodes	169
4.3 Methods and techniques of construction.....	174
4.4 Measurement of resistance to earth.....	176
4.5 Normative references	182
Chapter 5	
Electronic equipment grounding.....	187
5.1 Introduction.....	187
5.2 Definitions.....	187
5.3 History of computer grounding.....	188
5.4 System or equipment to be grounded.....	190
5.5 Grounding electronic equipment.....	191
5.6 Effects of internal rectifiers in computers.....	200
5.7 Grounding of shields.....	201
5.8 Interference from radio frequencies	204
5.9 Case histories	205
5.10 Normative references	207
5.11 Bibliography	208
Index	211

IEEE Recommended Practice for Grounding of Industrial and Commercial Power Systems

Chapter 1 System grounding

1.1 Introduction

1.1.1 Overview

This chapter provides recommended procedures for the system grounding of industrial and commercial power systems, and the proper selection and application of grounding impedances. Special cases of system grounding are also addressed for generators, uninterruptible power supplies (UPS), portable mining equipment, and multi-voltage systems.

1.1.2 General

Grounding of an electrical system is a decision that must be faced sometime by most engineers charged with planning or modifying electrical distribution. Grounding in some form is generally recommended, although there are certain exceptions. Several methods and criteria exist for system grounding; each has its own purpose.

It is the intention of this chapter to assist the engineer in making decisions on the subject by presenting basic reasons for grounding or not grounding and by reviewing general practices and methods of system grounding.

The practices set forth herein are primarily applicable to industrial power systems that distribute and utilize power at medium or low voltage, usually within a smaller geographical area than is covered by a utility.

Where distances or power levels may dictate circuitry and equipment similar to a utility, consideration of utility practices is warranted. However, restrictions of the National Electrical Code[®] (NEC[®]), NFPA 70¹ particular needs of service and the experience and training of the workforce should also be considered.

¹Information on references can be found in 1.16.

Where an industrial power system includes power-generating equipment, the reasons for grounding these components may be the same as those for grounding similar components of public utility systems. The methods of grounding would generally be similar under like conditions of service. However, in the industrial setting, conditions of service may be altered by the following:

- a) Location within the power system
- b) Individual generator characteristics
- c) Manufacturing process requirements

All of these may affect grounding decisions.

The NEC, sponsored by the National Fire Protection Association, contains regulations pertaining to system and equipment grounding applicable to industrial, commercial, and special occupancy facilities. These rules are considered minimum requirements for the protection of life and property and should be carefully reviewed during the course of system design. The recommended practices in this document are intended to supplement, and not negate, any of the requirements in the NEC.

1.2 Definitions

For the purposes of this document, the following terms and definitions apply. *The Authoritative Dictionary of IEEE Standards Terms* [B8]² and the NEC should be referenced for terms not defined in this subclause.

1.2.1 effectively grounded: Grounded through a sufficiently low impedance such that for all system conditions the ratio of zero-sequence reactance to positive-sequence reactance (X_0/X_1) is positive and not greater than 3, and the ratio of zero-sequence resistance to positive-sequence reactance (R_0/X_1) is positive and not greater than 1.

1.2.2 equipment grounding conductor (EGC): The conductor used to connect the non-current-carrying metal parts of the equipment, raceways, and other enclosures to the system grounded conductor, the grounding electrode conductor (GEC), or both, at the service equipment or at the source of a separately derived system.

1.2.3 ground: A conducting connection, whether intentional or accidental, between an electrical circuit or equipment and the earth, or to some other body that serves in place of the earth.

1.2.4 grounded: Connected to earth or to an extended conducting body that serves instead of the earth, whether the connection is intentional or accidental.

1.2.5 grounded system: A system in which at least one conductor or point (usually the middle wire or neutral point of transformer or generator windings) is intentionally grounded, either solidly or through an impedance.

²The numbers in brackets correspond to those of the bibliography in 1.17.

1.2.6 grounding system: A system that consists of all interconnected grounding connections in a specific power system and is defined by its isolation from adjacent grounding systems. The isolation is provided by transformer primary and secondary windings that are coupled only by magnetic means. Thus, the system boundary is defined by the lack of a physical connection that is either metallic or through a significantly high impedance.

1.2.7 high-resistance grounded: A resistance-grounded system designed to limit ground-fault current to a value that can be allowed to flow for an extended period of time, while still meeting the criteria of $R_0 < X_{c0}$, so that transient voltages from arcing ground faults are reduced. The ground-fault current is usually limited to less than 10 A, resulting in limited damage even during prolonged faults.

1.2.8 low-resistance grounded: A resistance-grounded system that permits a higher ground-fault current to flow to obtain sufficient current for selective relay operation. Usually meets the criteria of R_0/X_0 less than or equal to 2. Ground-fault current is typically between 100 A and 1000 A.

1.2.9 per-phase charging current (I_{c0}): The current (V_{ln}/X_{c0}) that passes through one phase of the system to charge the distributed capacitance per phase-to-ground of the system; V_{ln} is the line-to-neutral voltage and X_{c0} is the per-phase distributed capacitive reactance of the system.

1.2.10 reactance grounded: Grounded through an impedance, the principal element of which is inductive reactance.

1.2.11 resistance grounded: Grounded through an impedance, the principal element of which is resistance.

1.2.12 resonant grounded: A system in which the capacitive charging current is neutralized by an inductive current produced from a reactor connected between the system neutral and ground. By properly “tuning” the reactor (selecting the right tap), a low magnitude of fault current can be achieved. In general, when this occurs the arc will not maintain itself and the ground fault is extinguished or “quenched.” In a parallel circuit, consisting of L and C, this happens when,

$$\omega L = \frac{1}{\omega C} \quad \text{or} \quad f = \frac{1}{2\pi\sqrt{LC}}$$

1.2.13 R_n : The value of the resistance connected from the neutral to the ground of a resistance-grounded system. For high-resistance grounded systems where R_n is a major component of R_0 , the relationship $R_0 = 3R_n$ applies.

1.2.14 R_0 : The per-phase zero-sequence resistance of the system.

1.2.15 separately derived system: A wiring system whose power is derived from a generator, transformer, or converter windings and has no direct electrical connection,

including a solidly connected grounded circuit conductor, to supply conductors originating in another system.

1.2.16 solidly grounded: Connected directly through an adequate ground connection in which no impedance has been intentionally inserted.

1.2.17 static charge: The electricity generated when two dissimilar substances come into contact. Conveyor belts are active producers of static electricity.

1.2.18 switching surge: A transient wave of overvoltage in an electric circuit caused by the operation of a switching device interrupting current.

1.2.19 system charging current: The total distributed capacitive charging current ($3V_{ln}/X_{co}$) of a three-phase system.

1.2.20 three-phase, four-wire system: A system of alternating current supply comprising four conductors, three of which are connected as in a three-phase three-wire system, the fourth being connected to the neutral point of the supply or midpoint of one phase in case of delta-connected transformer secondary for the purpose of conducting load current.

1.2.21 three-phase, three-wire system: A system of alternating current supply comprising three conductors, between successive pairs of which are maintained alternating differences of potential successively displaced in phase by one third of a period.

1.2.22 transient overvoltage: The temporary overvoltage associated with the operation of a switching device, a fault, a lightning stroke, an arcing ground fault on an ungrounded system, or other instigating events.

1.2.23 ungrounded system: A system without an intentional connection to ground except through potential indicating or measuring devices or other very high-impedance devices.

1.2.24 X_{co} : The distributed per-phase capacitive reactance to ground of the system.

1.2.25 X_0 : Zero-sequence reactance of the system.

1.2.26 X_1 : Positive-sequence reactance of the system.

1.2.27 X_2 : Negative-sequence reactance of the system.

1.3 Purposes of system grounding

System grounding is the intentional connection to ground of a phase or neutral conductor for the purpose of:

- a) Controlling the voltage with respect to earth, or ground, within predictable limits, and

- b) Providing for a flow of current that will allow detection of an unwanted connection between system conductors and ground. Such detection may then initiate operation of automatic devices to remove the source of voltage from these conductors.

The NEC prescribes certain system grounding connections that must be made to be in compliance with the code. The control of voltage to ground limits the voltage stress on the insulation of conductors so that insulation performance can more readily be predicted. The control of voltage also allows reduction of shock hazard to persons who might come in contact with live conductors.

1.4 Methods of system neutral grounding

1.4.1 Introduction

Most grounded systems employ some method of grounding the system neutral at one or more points. These methods can be divided into two general categories: *solid grounding* and *impedance grounding*. Impedance grounding may be further divided into several subcategories: reactance grounding, resistance grounding, and *ground-fault neutralizer grounding*. Figure 1-1 shows examples of these methods of grounding.

Each method, as named, refers to the nature of the external circuit from system neutral to ground rather than to the degree of grounding. In each case the impedance of the generator or transformer whose neutral is grounded is in series with the external circuit. Thus a solidly grounded generator or transformer may or may not furnish effective grounding to the system, depending on the system source impedance.

Many of the concepts involved in defining system grounding types and levels are best explained in terms of symmetrical components or equivalent circuits. The reader who is not familiar with these analytical methods is referred to Chapter 2 of Beeman and to Chapter 3 of IEEE Std 399™ (*IEEE Brown Book™*) for guidance.

Molded-case circuit-breaker interrupting capabilities can be affected by the method of grounding. In addition, if other than solidly grounded wye systems are used, the circuit breakers' single-pole interrupting ratings should be evaluated for the application

1.4.2 Ungrounded system (no intentional grounding)

In an ungrounded system, there is no intentional connection between the system conductors and ground. However, as shown in Figure 1-2, there always exists a capacitive coupling between one system conductor and another, and also between system conductors and ground. Consequently, the so-called *ungrounded* system is in reality a *capacitance grounded* system, by virtue of the distributed capacitance from the system conductors to ground. Since the capacitance between phases has little effect on the grounding characteristics of the system, it will be disregarded. For simplicity, the distributed capacitive reactance to ground, X_{CO} , is assumed to be balanced.

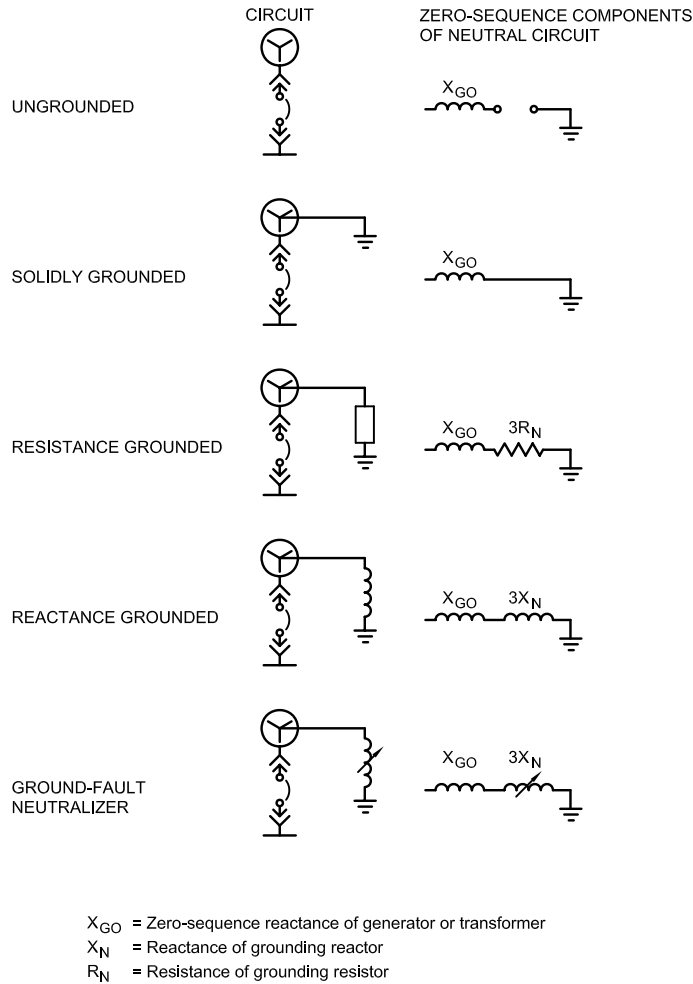

Figure 1-1—System neutral circuit and equivalent diagrams for ungrounded and grounded systems

In an unfaulted condition, with balanced three-phase voltages applied to the lines, the capacitive charging current, I_{C0} , in phase will be equal and displaced 120° from one another. The phase voltages to ground will also be equal and displaced 120° from one another. The vectors relationships are shown in part b) of Figure 1-2. Since the neutral of the distributed capacitances is at earth potential, it follows that the neutral of the transformer is also at earth potential, being held there by the capacitance to ground.

If one of the system conductors, phase C for example, faults to ground, current flow through that capacitance to ground will cease, since no potential difference across it now exists. The voltage across the remaining two distributed capacitors to ground will, however, increase from line to neutral to line to line. The capacitive charging current, I_{C0} ,

in the two unfaulted phases will therefore increase by the square root of 3. As shown in Figure 1-3, the line-to-ground voltages are no longer 120°, but 60° apart.

Hence, the vectorial sum of the capacitive charging current to ground is no longer zero, but is $3 I_{c0}$ or three times the original charging current per phase. The fault current, I_g , flowing from the faulted conductor to ground, leads the original line-to-neutral voltage ($V_{nc} = -V_{cn}$) by approximately 90°.

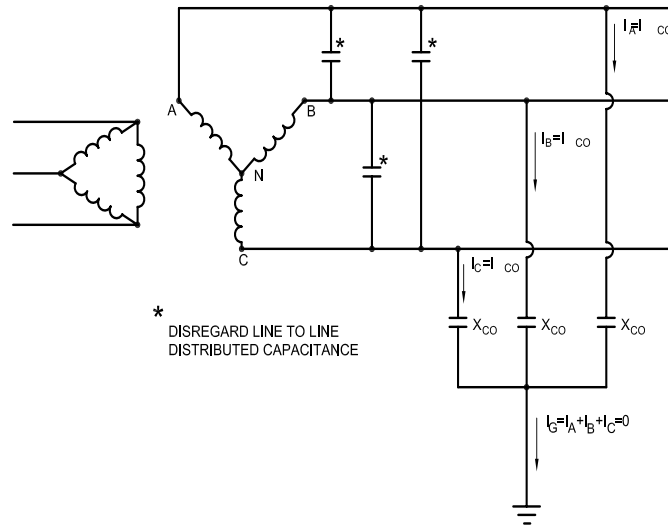

(a)

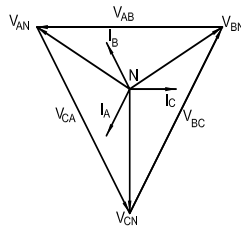

(b)

Figure 1-2—Ungrounded system: (a) circuit configuration, (b) vector diagram

In an ungrounded system, it is possible for destructive transient overvoltages to occur throughout the system during restriking ground faults. These overvoltages, which can be several times normal in magnitude, result from a resonant condition being established between the inductive reactance of the system and the distributed capacitance to ground. This phenomenon is discussed in detail by Beeman. Experience has proved that these

overvoltages may cause failure of insulation at multiple locations in the system, particularly at motors. Transient overvoltages from restriking ground faults are the main reason why ungrounded systems are no longer recommended and grounded systems of some form are the predominant choice. To reduce transient overvoltages during restriking ground faults, one should ground the system using either solid or impedance grounding as indicated in Figure 1-4.

Various detection schemes are used to detect the presence of a single line-to-ground fault. The simplest scheme employs three light bulbs, each connected between line voltage and ground. Under normal operation the three bulbs are illuminated with low equal intensity. When a single line-to-ground fault occurs, that bulb connected to the faulted phase is extinguished. The remaining two bulbs increase in intensity, since the voltage on the unfaulted phases increases from line-to-neutral to line-to-line.

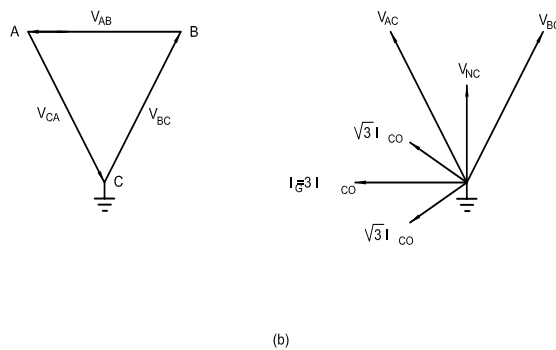
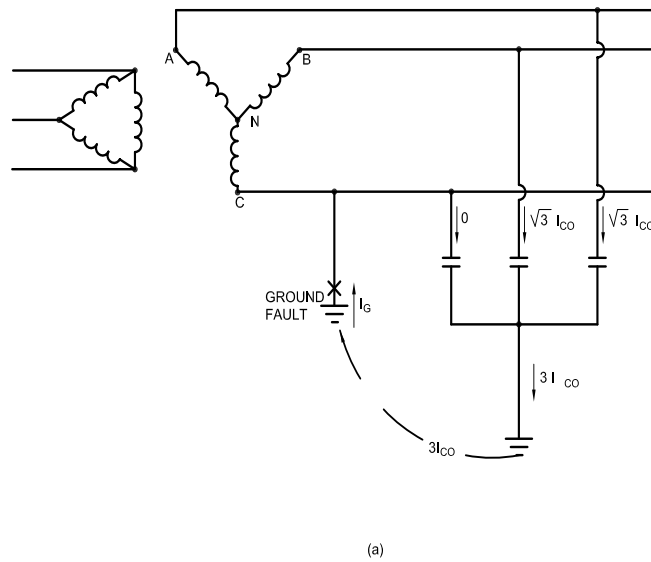

**Figure 1-3—Single line-to-ground fault on an ungrounded system:
(a) circuit configuration, (b) vector diagram**

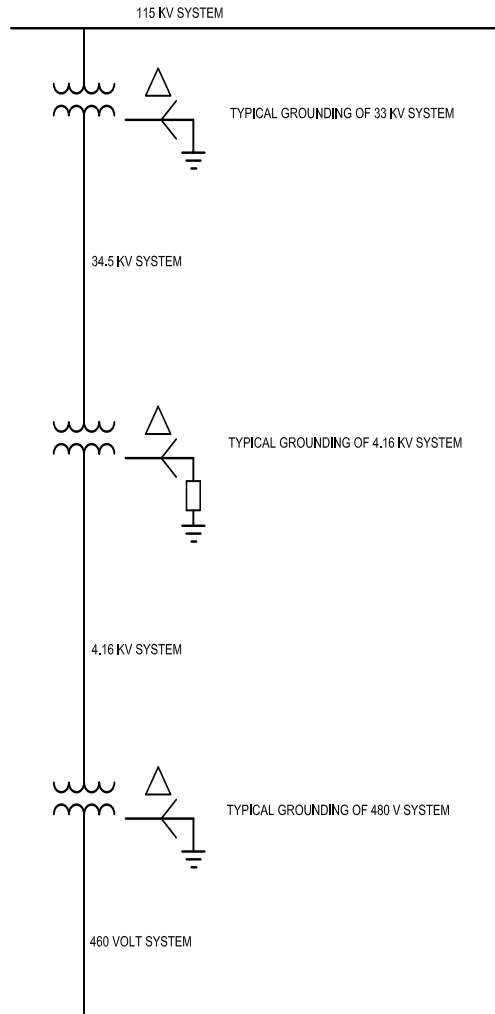

Figure 1-4—Independent grounding of each voltage level

Another scheme frequently used takes the form of three voltage transformers with their primary windings connected in wye and the neutral point grounded. The secondary windings of the transformers are connected in broken delta, with a voltage relay connected in the open corner and used to operate an indication or alarm circuit. Using this scheme, loading resistors may be required either in the primary neutral or secondary circuit to avoid ferroresonance.

The problem of locating a single line-to-ground fault on an ungrounded system can be time consuming. Usually, the first step is to open the secondary feeders, one at a time, to determine on which feeder the fault is located. Afterwards, the branch circuits are opened one at a time. Finally, the individual loads are taken off. None of these procedures improves service continuity.

If a ground cannot be located before a second line-to-ground fault occurs, whose current must be carried by the EGC or earth, the result will be a line-to-line fault. This will be contrasted later to a grounded system that develops enough ground current to clear, automatically and selectively, each faulted circuit.

1.4.3 Resistance grounding

In a resistance-grounded system, the neutral of the transformer or generator is connected to ground through a resistor. A typical resistance-grounded neutral system is shown in Figure 1-5. As commonly installed, the resistance has a considerably higher ohmic magnitude than the system reactance at the resistor location. Consequently, the line-to-ground fault current is primarily limited by the resistor itself.

The reasons for limiting the current by resistance grounding include the following:

- a) To reduce burning and melting effects in faulted electric equipment, such as switchgear, transformers, cables, and rotating machines.
- b) To reduce mechanical stresses in circuits and apparatus carrying fault currents.
- c) To reduce electric-shock hazards to personnel caused by stray ground-fault currents in the ground-return path.
- d) To reduce the arc blast or flash hazard to personnel who may have accidentally caused or happen to be in close proximity to the ground fault.
- e) To reduce the momentary line-voltage dip occasioned by the occurrence and clearing of a ground fault.
- f) To secure control of transient overvoltages while at the same time avoiding the shutdown of a faulted circuit on the occurrence of the first ground fault (high-resistance grounding).

Resistance grounding may be either of two classes, high resistance or low resistance, distinguished by the magnitude of ground-fault current permitted to flow. Although there are no recognized standards for the levels of ground-fault current that define these two classes, in practice there is a clear difference.

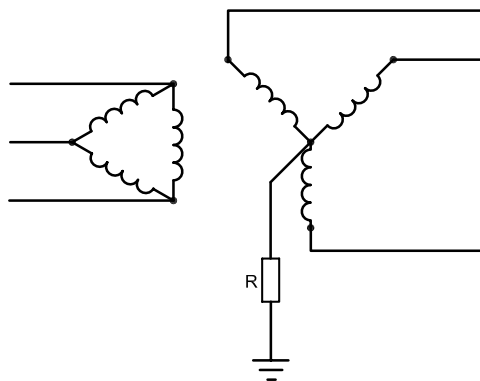

Figure 1-5—Resistance-grounded system

1.4.3.1 High-resistance grounding

High-resistance grounding employs a neutral resistor of high ohmic value. The value of the resistor is selected to limit the current, I_r , to a magnitude equal to or slightly greater than the total capacitance charging current, $3 I_{co}$, as shown in Figure 1-6.

Typically, the ground-fault current, I_g , is limited to 10 A or less, although some specialized systems at voltages in the 15 kV class may require higher ground-fault levels. In general, the use of high-resistance grounding on systems where the line-to-ground fault exceeds 10 A should be avoided because of the potential damage caused by an arcing current larger than 10 A in a confined space (see Foster, Brown, and Pryor).

Several references are available that give typical system charging currents for major items in the electrical system (see *Electrical Transmission and Distribution Reference Book*; Baker). These will allow the value of the neutral resistor to be estimated in the project design stage. The actual system charging current may be measured prior to connection of the high-resistance grounding equipment following the manufacturer’s recommended procedures.

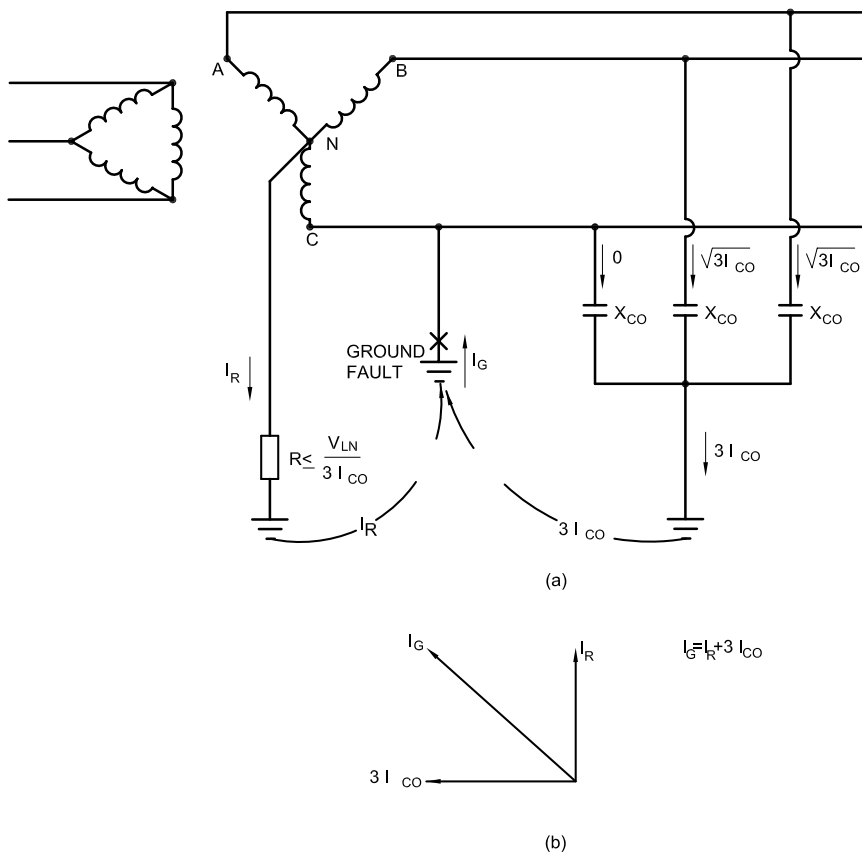

Figure 1-6—Single line-to-ground fault on a high-resistance grounded system: (a) circuit configuration, (b) vector diagram

High-resistance grounding usually does not require immediate clearing of a ground fault since the fault current is limited to a very low level. The protective scheme associated with high-resistance grounding is usually detection and alarm rather than immediate trip out.

A typical scheme for detecting a ground fault in a high-resistance grounded system is shown in Figure 1-7. Under normal operation, the neutral point of the transformer is at zero potential. When a single line-to-ground fault occurs, the neutral point is raised to approximately line-to-neutral voltage. This rise in voltage is then detected using an overvoltage relay, 59. A step-down transformer is typically used to reduce the line to neutral voltage of the system to a level (usually 120 V) acceptable to the relay. Since a ground fault may persist for an indefinite length of time, a continuous (rather than short term) rating should be imposed on the grounding resistor.

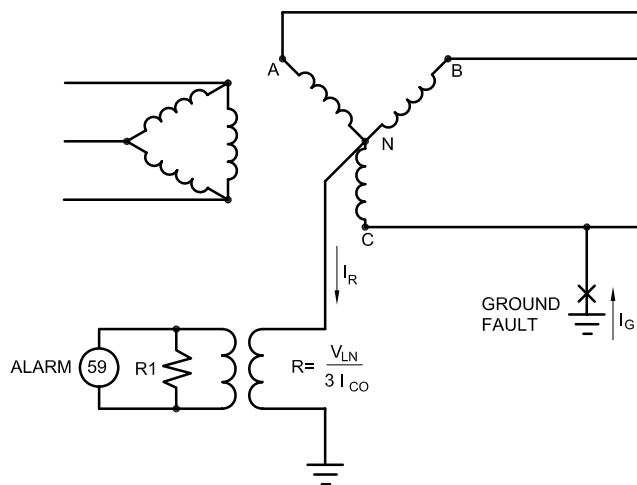

Figure 1-7—Scheme for detecting a ground fault on a high-resistance grounded system

High-resistance grounding has the following advantages:

- a) Service continuity is maintained. The first ground fault does not require process equipment to be shut down.
- b) Transient overvoltage due to restriking ground faults is reduced (to 250% of normal).
- c) A signal tracing or pulse system will facilitate locating a ground fault.
- d) It eliminates flash hazards to personnel associated with high ground-fault currents.
- e) The need for and expense of coordinated ground-fault relaying is eliminated.

High-resistance grounding is generally employed in the following:

- 1) Low voltage (where permitted), i.e., commercial and industrial locations where there are no line-to-neutral loads.

- 2) Medium-voltage systems where service continuity is desired and capacitive charging current is not excessive.
- 3) Retrofits of previously ungrounded systems where it is desired to reduce transient overvoltages potentially caused by restriking ground faults.

1.4.3.2 Low-resistance grounding

Low-resistance grounding is designed to limit ground-fault current to a range between 100 A and 1000 A, with 400 A being typical. The neutral resistor, R , shown in Figure 1-8, is selected according to $R = V_{LN}/I_g$, where V_{LN} is the system line to neutral voltage and I_g is the desired ground-fault current. Figure 1-9 illustrates the flow of currents for a single line-to-ground fault on a low-resistance grounded system. Since the combined effects of charging current and system source impedance will affect the ground-current value less than 0.5% in the typical range of utility supplied systems, it is permissible to ignore these effects in calculating the ground-fault resistance value. The general practice is to consider that the full system line-to-neutral voltage appears across the grounding resistor. Only in the case of systems supplied by small generators should departure from this general practice be considered.

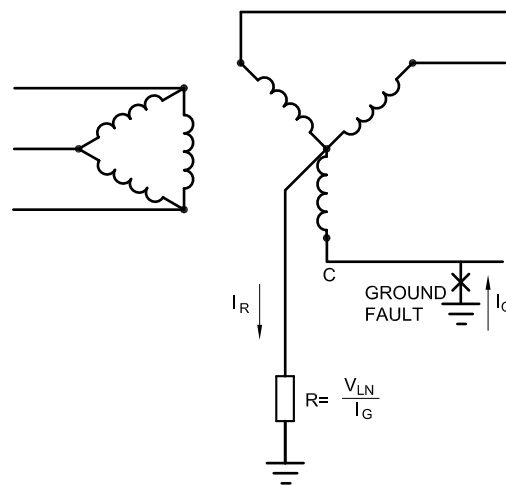

Figure 1-8—Low-resistance grounded system

Low-resistance grounding has the advantage of facilitating the immediate and selective clearing of a grounded circuit. This requires that the minimum ground-fault current be large enough to positively actuate the applied ground-fault relay. One method of detecting the presence of a ground fault uses an overcurrent relay, 51G. This method is presented in Figure 1-10. When a ground fault occurs, the neutral potential is raised to approximately line-to-neutral voltage, resulting in current flow through the resistor. A typical turns ratio for the current transformer is indicated. Upon indication that a ground fault has occurred, action would be initiated to disconnect the transformer from the secondary circuit.

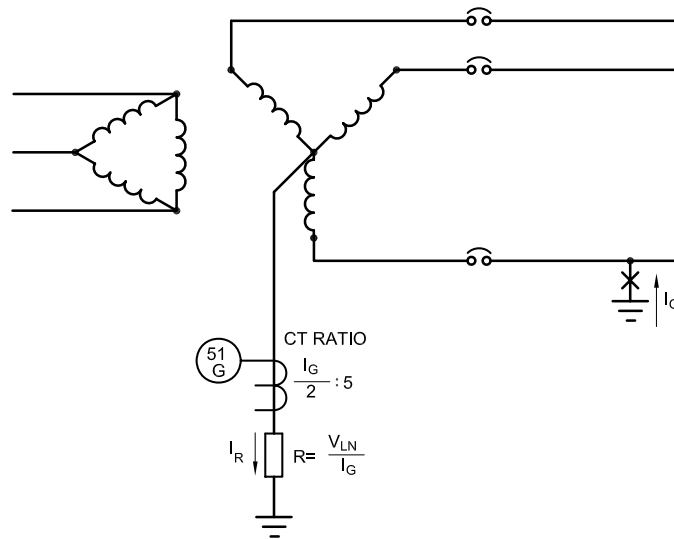

Figure 1-10—Scheme for detecting a ground fault on a low-resistance grounded system

1.4.4 Reactance grounding

The term *reactance grounding* describes the case in which a reactor is connected between the system neutral and ground, as shown in Figure 1-11. Since the ground fault that may flow in a reactance-grounded system is a function of the neutral reactance, the magnitude of the ground-fault current is often used as a criterion for describing the degree of grounding. In a reactance-grounded system, the available ground-fault current should be at least 25% ($X_0 = 10X_1$) and preferably 60% ($X_0 = 3X_1$) of the three-phase fault current to prevent serious transient overvoltages. The term X_0 , as used, is the sum of the source zero-sequence reactance, X_0 , plus three times the grounding reactance, $3X_n$, ($X_0 = X_{0 \text{ source}} + 3X_n$). This is considerably higher than the level of fault current desirable in a resistance-grounded system, and therefore reactance grounding is usually not considered an alternative to low-resistance grounding.

Reactance grounding is typically reserved for applications where there is a desire to limit the ground-fault duty to a magnitude that is relatively close to the magnitude of a three-phase fault. Use of neutral grounding reactors to provide this fault limitation will often be found to be a less expensive application than use of grounding resistors if the desired current magnitude is several thousand amperes.

These circumstances may arise in one of two possible instances. One potential setting is where a large substation feeds a medium-voltage distribution system, and the total zero-sequence impedance of the step-down transformers in the station causes the single-line-to-ground-fault current to greatly exceed the magnitude of a three-phase fault, and ground-fault limitation is desired to keep the total fault current within the reasonable limits. These conditions tend to occur most often in electric utility distribution practice.

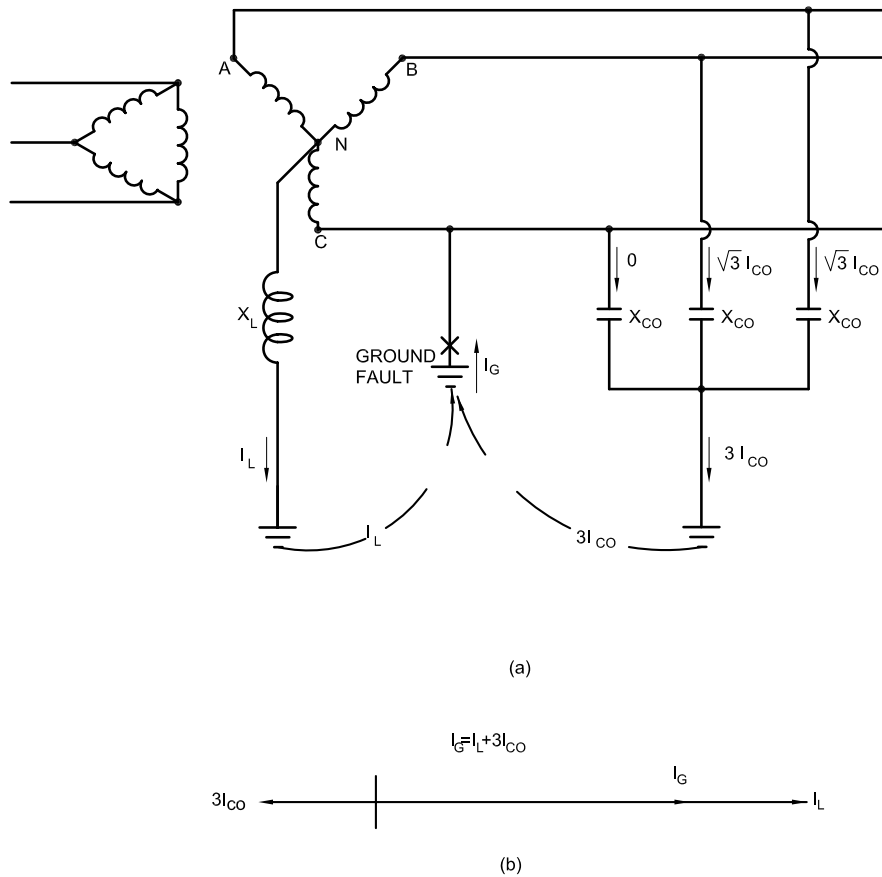

Figure 1-11—Single line-to-ground fault on a low reactance grounded system: (a) circuit configuration, (b) vector diagram

The second instance is where there is a desire to serve single-line-to-neutral-connected load directly at the terminal voltage of generators, i.e., without an intervening generator isolation transformer. In this instance, a current will flow in the generator neutral as a result of unbalance between the loads on the three phases. A resistor in the neutral circuit of the generator will limit the flow of this unbalance, thereby limiting the ability of the system to carry unbalanced single-phase load. Medium-voltage generators are typically not designed to withstand the unbalanced mechanical forces associated with supplying ground-fault currents that exceed the magnitude of current that the machine would produce to a three-phase fault at its terminals, thereby making solid grounding of the neutral undesirable. Use of low-reactance grounding to limit the ground-fault magnitude to a level slightly lower than the three-phase level is a way to resolve these application constraints. The conditions that favor low-reactance grounding of generators are relatively rare, so this practice is somewhat obscure.

1.4.5 Resonant grounding (ground-fault neutralizer)

A ground-fault neutralizer is a reactor connected between the neutral of a system and ground. The reactor, X_1 , is specially selected, or *tuned*, to resonate with the distributed capacitance, X_{co} of the system so that a resulting ground-fault current is resistive and low in magnitude. A resistance, r , is shown depicting reactor losses. The resulting ground-fault current is in phase with the line to neutral voltage so that current zero and voltage zero occur simultaneously. If the ground fault is in air, such as an insulator flashover, it may be self-extinguishing.

Operation of a ground-fault neutralizer is explained with reference to Figure 1-12. The distributed capacitance per phase is assumed to be balanced. When one phase of the system is grounded (assume phase C) a line-to-neutral voltage, V_{cn} , is impressed across the reactor. This produces a lagging inductive current, I_l , that flows from the neutralizer through the transformer, to the fault, then to the ground. At the same time a leading capacitive current, $3 I_{co}$, flows from the two unfaulted lines through the capacitance to ground and to the fault. The lagging current from the inductor and the leading current from the distributed capacitance are practically 180° out of phase. By properly tuning the reactor (selecting the right tap), the inductive and capacitive components of current can be made to neutralize each other, leaving only a relatively small component of resistive current, I_r , to flow in the fault.

This method of grounding formerly was occasionally seen in high-voltage transmission practice. Today, it is rarely encountered in North America. There are a few instances in which it has been applied for generator grounding in large central stations, especially in the New England area. However, it is relatively common in electric utility distribution practice in the UK and Europe. A key requirement is that because the resonant circuit must be retuned if the distributed parameters of the associated circuit are changed, the ideal application is one that does not involve frequent circuit switching or reconfiguration.

1.4.6 Solid grounding

Solid grounding refers to the connection of a system conductor, usually the neutral of a generator, power transformer, or grounding transformer directly to ground, without any intentional intervening impedance. However, both the impedance of the source and the unintentional impedance in the connection to ground must be considered when evaluating the grounding. Two examples of solidly grounded systems are shown in Figure 1-13.

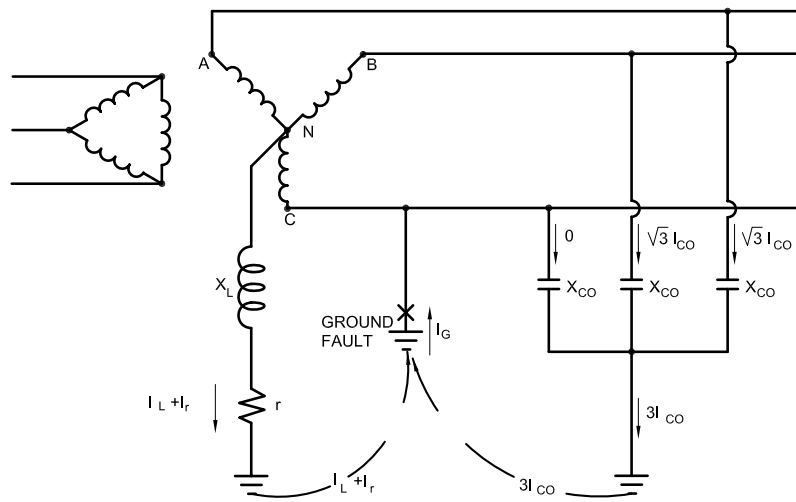

(a)

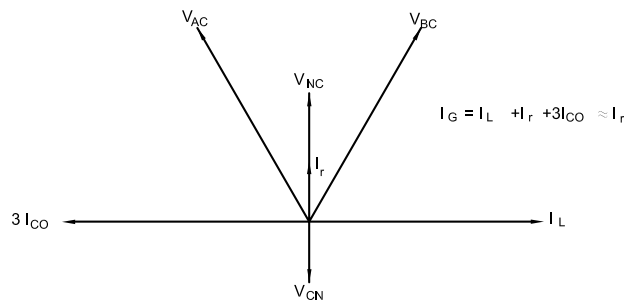

(b)

**Figure 1-12—Single line-to-ground fault on a resonant grounded system:
(a) circuit configuration, (b) vector diagram**

To assess the benefits of a solid connection to ground, it is necessary to determine the degree of grounding provided in the system. A good guide in answering this question is the magnitude of ground-fault current as compared to the system three-phase fault current. The higher the ground-fault current in relation to the three-phase fault current, the greater the degree of grounding in the system. Effectively grounded systems will have a line-to-ground short-circuit current of at least 60% of the three-phase, short-circuit value. In terms of resistance and reactance, effective grounding of a system is accomplished only when $R_0 \leq X_1$ and $X_0 \leq 3X_1$ and such relationships exist at all points in the system. The X_1 component used in the above relation is the Thevenin equivalent positive-sequence

reactance of the complete system including the subtransient reactance of all rotating machines. The R_0 component is primarily three times the resistance of the connection to ground.

Because the reactance of a solidly grounded generator or transformer is in series with the neutral circuit (see Figure 1-1), a solid connection does not provide a zero impedance circuit. If the reactance of the system zero-sequence circuit is too great with respect to the system positive-sequence reactance, the objectives sought in grounding, principally freedom from transient overvoltages, may not be achieved. If R_0 is too high it may not create transient voltages, but it may also not provide desired suppression of voltage to ground on the unfaulted phases.

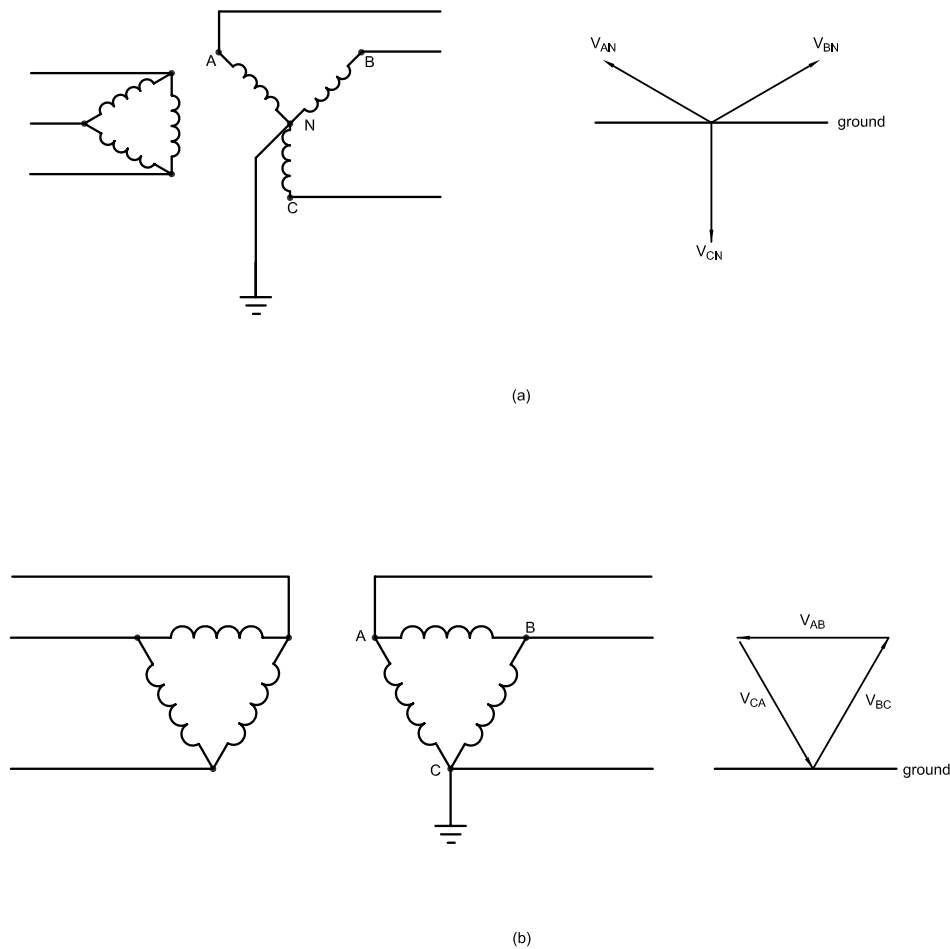

Figure 1-13—Solidly grounded systems: (a) grounded wye, (b) corner grounded delta

This is rarely a problem in typical industrial and commercial power systems. A sufficiently low resistance to earth may be difficult to achieve, but the “ground” to which faults occur will be the bonded conductive electrical enclosures. The zero-sequence impedance of most generators used in these systems is much lower than the positive-sequence impedance of these generators. The zero-sequence impedance of a delta-wye transformer will not exceed the transformer’s positive-sequence impedance. There are, however, conditions under which relatively high zero-sequence impedance may occur.

One of these conditions is a power system fed by several generators and/or transformers in parallel. If the neutral of only one source is grounded, it is possible for the zero-sequence impedance of the grounded source to exceed the effective positive-sequence impedance of the several sources in parallel.

Another such condition may occur where power is distributed to remote facilities by an overhead line without a metallic ground-return path. In this case, the return path for ground-fault current is through the earth, and even though both the neutral of the source and the non-conducting parts at the load may be grounded with well-made electrodes, the ground-return path includes the impedance of both of these ground electrodes. This impedance may be significant. Another significant source of zero-sequence impedance is the large line-to-ground spacing of the overhead line.

Solid grounding is generally recommended for the following:

- a) Low-voltage systems (600 V and below) where automatic isolation of a faulted circuit can be tolerated or where capability is lacking to isolate a ground fault in a high-resistance grounded system.
- b) Medium- or high-voltage systems (above 15 kV) in order to permit the use of equipment with insulation levels to ground rated for less than line to line voltage.
- c) Medium- or high-voltage applications where the desire for a higher magnitude of ground-fault current in order to be able to provide selective ground-fault detection on lengthy distribution feeders outweighs concerns about arc flash and potential gradients as personnel hazards in a workplace setting.

1.4.7 Characteristics of grounding methods

The advantages and disadvantages of the various methods of grounding are summarized in Table 1-1.

Table 1-1—Characteristics of grounding methods

	Ungrounded	Solid grounding	Reactance grounding		Ground-fault neutralizer	Resistance grounding	
			Low value reactor	High value reactor		Low resistance	High resistance
Current for phase-to-ground fault in percent of three-phase fault current	Less than 1%	Varies, may be 100% or greater	Usually designed to produce 25% to 100%	5% to 25%	Nearly zero fault current	20% and downward to 100 A to 1000 A	Less than 1% but not less than system charging current, $3I_{co}$
Transient over-voltages	Very high	Not excessive	Not excessive	Not excessive	Not excessive	Not excessive	Not excessive
Surge arresters	Ungrounded-neutral type	Grounded-neutral type	Grounded-neutral type if current 60% or greater	Ungrounded-neutral type	Ungrounded-neutral type	Ungrounded-neutral type	Ungrounded-neutral type
Remarks	Not recommended due to overvoltages and non-segregation of fault	Generally used on systems (1) 600 V and below and (2) over 15 kV	Not used due to excessive overvoltages	Best suited for application in most medium-voltage industrial and commercial systems that are isolated from their electric utility system by transformers. ^a	Generally used on systems of 2.4 kV to 15 kV particularly where large rotating machines are connected.	Used on systems 600 V and below where service continuity is desired. ^a	

^aCaution should be applied in using this form of grounding with industrial generation (see IEEE Std 36.7™). Best suited for application in most medium-voltage industrial and commercial systems that are isolated from their electric utility system by transformers. Ideal for use on medium-voltage generators. Also occasionally found on mission-critical 2.4 kV or 4.16 kV industrial or commercial distribution systems.

1.5 Obtaining the system neutral

The best way to obtain the system neutral for grounding purposes in three-phase systems is to use source transformers or generators with wye-connected windings. The neutral is then readily available. Such transformers are available for practically all voltages except 240 V. On new systems, 208Y/120 V or 480Y/277 V, wye-connected transformers may be used to good advantage instead of 240 V. Wye-connected source transformers for 2400 V, 4160 V, and 13 800 V systems are available as a standard option, whereas 4800 V and 6900 V, wye-connected source transformers may be priced at a premium rate. The alternative is to apply grounding transformers.

1.5.1 Grounding transformers

System neutrals may not be available, particularly in many older systems rated 600 V or less and in many existing 2400 V, 4800 V, and 6900 V systems. When existing delta connected or ungrounded systems are to be grounded, grounding transformers can be used to obtain a neutral. The most commonly used grounding transformers are the zigzag and wye-delta type.

1.5.2 Zigzag grounding transformers

One type of grounding transformer commonly used is a three-phase zigzag transformer with no secondary winding. The internal connection of the transformer is illustrated in Figure 1-14(1). The impedance of the transformer to balanced three-phase voltages is high so that when there is no fault on the system, only a small magnetizing current flows in the transformer winding. The transformer impedance to zero-sequence voltages, however, is low so that it allows high ground-fault currents to flow. The transformer divides the ground-fault current into three equal components; these currents are in phase with each other and flow in the three windings of the grounding transformer. The method of winding is seen from Figure 1-14(1) to be such that when these three equal currents flow, the current in one section of the winding of each leg of the core is in a direction opposite to that in the other section of the winding on that leg. This tends to force the ground-fault current to have equal division in the three lines and accounts for the low impedance of the transformer-to-ground currents.

A zigzag transformer may be used for effective grounding, or an impedance can be inserted between the derived neutral of the zigzag transformer and ground to obtain the desired method of grounding. This transformer is seldom employed for medium-voltage, high-resistance grounding. An example of low-resistance grounding is shown in Figure 1-14(2). The overcurrent relay, 51G, is used to sense neutral current that only flows during a line-to-ground fault.

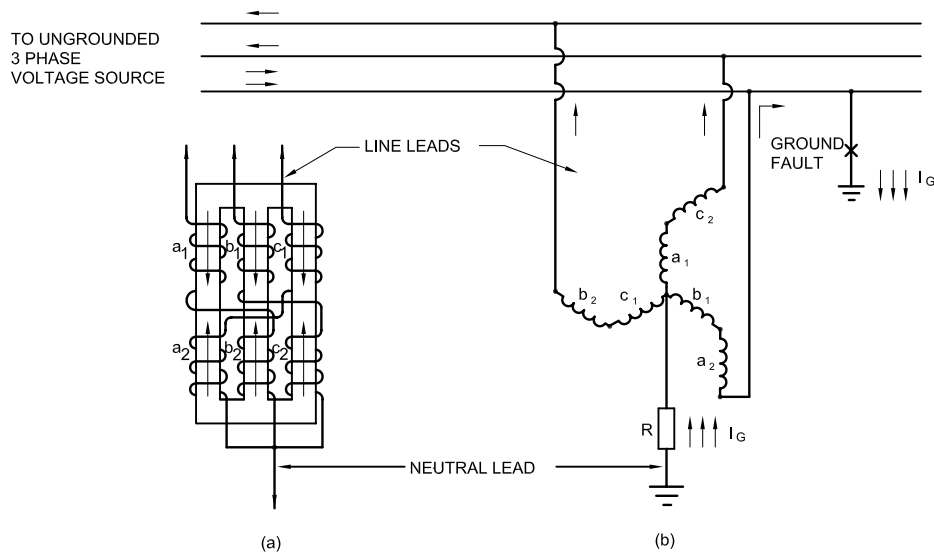

Figure 1-14(1)—Zigzag grounding transformer: (a) core windings, (b) system connection

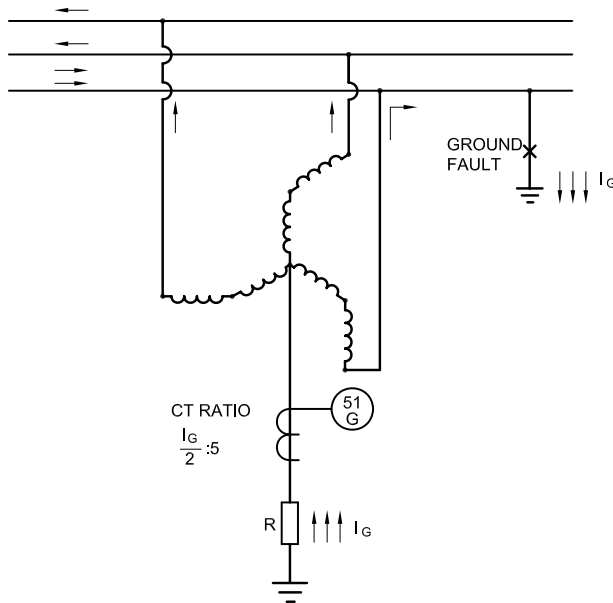

Figure 1-14(2)—Low-resistance grounding of system through a zigzag grounding transformer with neutral sensing current relay

1.5.3 Wye-delta grounding transformers

A wye-delta connected three-phase transformer or transformer bank can also be utilized for system grounding, as shown in Figure 1-15(a) and Figure 1-15(b). As in the case of the zigzag transformer, it can be used for effective grounding or to accomplish resistance-type grounding of an existing ungrounded system. The delta connection must be closed to provide a path for the zero-sequence current, and the delta voltage rating is selected for any standard value. A resistor inserted between the primary neutral and ground, as shown in Figure 1-15(a) and Figure 1-15(b), provides a means for limiting ground-fault current to a level satisfying the criteria for resistance-grounded systems. For this arrangement, the voltage rating of the wye winding need not be greater than the normal line-to-neutral system voltage. A neutral sensing current relay, 51G, is shown for detection of a single line-to-ground fault. For high-resistance grounding it is sometimes more practical or economical, as illustrated in Figure 1-16, to apply the limiting resistor in the secondary delta connection. For this configuration the grounding bank must consist of three single-phase transformers with the primary wye neutral connected directly to ground. The secondary delta is closed through a resistor that effectively limits the primary ground-fault current to the desired low level. For this alternative application, the voltage rating of each of the transformer windings forming the wye primary should not be less than the system line-to-line voltage.

The rating of a three-phase grounding transformer or bank, in kilovoltampere (kVA), is equal to the rated line-to-neutral voltage in kilovolts times the rated neutral current (see *Electrical Transmission and Distribution Reference Book*). Most grounding transformers are designed to carry their rated current for a limited time only, such as 10 s or 1 min. Consequently, they are much smaller in size than an ordinary three-phase continuously rated transformer with the same rating.

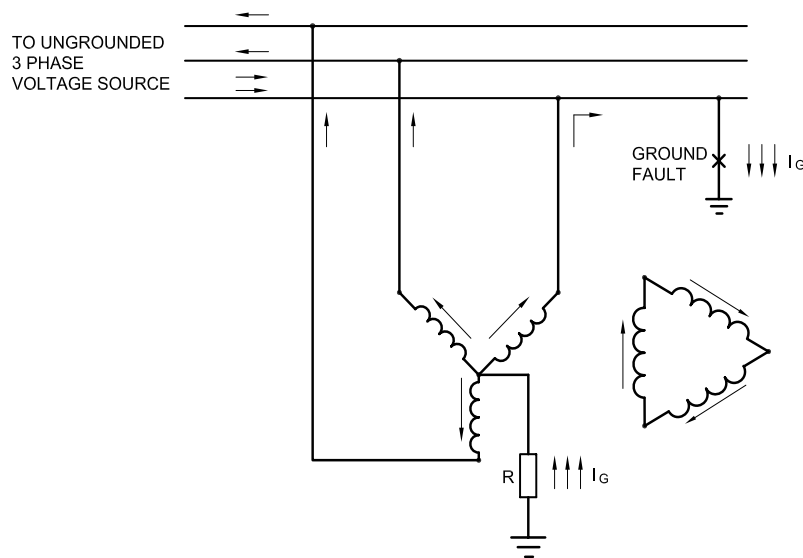

Figure 1-15(a)—Wye-delta grounding transformer showing current flow

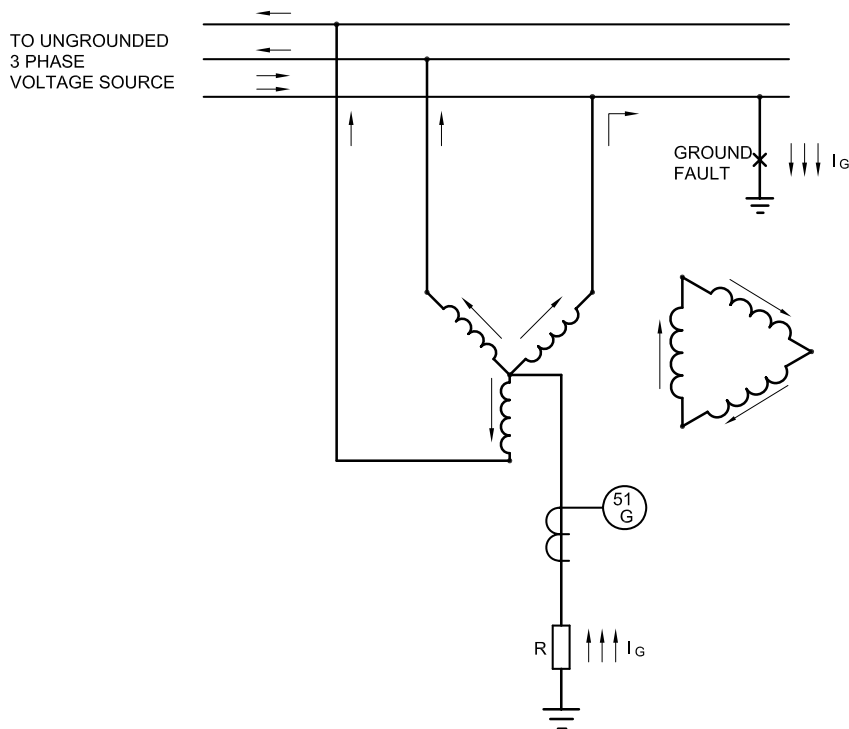

Figure 1-15(b)—Low-resistance grounding of system through a wye-delta grounding transformer with neutral sensing current relay

It is generally desirable to connect a grounding transformer directly to the main bus of a power system, without intervening circuit breakers or fuses, to prevent the transformer from being inadvertently taken out of service by the operation of the intervening devices. (In this case the transformer is considered part of the bus and is protected by the relaying applied for bus protection.) Alternatively, the grounding transformer should be served by a dedicated feeder circuit breaker, as shown in part a) of Figure 1-17, or connected between the main transformer and the main switchgear, as illustrated in part b) of Figure 1-17. If the grounding transformer is connected as shown in part b) of Figure 1-17, there should be one grounding transformer for each delta-connected bank supplying power to the system, or enough grounding transformers to assure at least one grounding transformer on the system at all times. When the grounding transformer is so connected, it is included in the protective system of the main transformer.

1.5.4 Grounding at points other than system neutral

In some cases, low-voltage systems (600 V and below) are grounded at some point other than the system neutral to obtain a grounded electrical system. This is done because delta transformer connections do not provide access to the three-phase system neutral. Two systems are in general use.

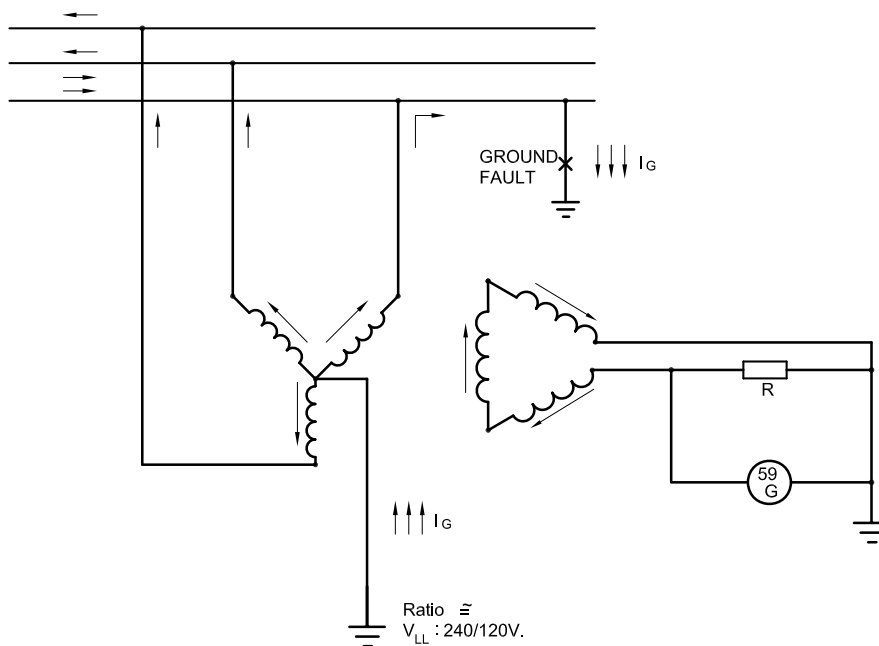

Figure 1-16—High-resistance grounding of system through a wye-broken delta grounding transformer with neutral sensing voltage relay

1.5.5 Corner-of-the-delta grounded systems

Some low-voltage, ungrounded systems, have been conceived, as shown in part b) of Figure 1-13, using delta connected supply transformers with no readily available neutral grounding. Because of its limitations, this type of grounding is no longer popular and is not widely used in industrial systems.

1.5.6 One phase of a delta system grounded at midpoint

In some areas where the utility has both a single-phase 120/240 V load and three-phase 240 V loads, they have supplied a larger single-phase 120/240 V transformer and one or two smaller 240 V transformers, all connected in delta with the midpoint of the 120/240 V grounded for a 240/120 V three-phase four-wire system. This provides neutral grounding for the single-phase 120/240 V and also grounding for the 240 V three-phase system. It is not recommended for voltages over 240 V.

The advantages of this type of grounding scheme are as follows:

- a) First cost for transformers and fuses can be less than for separate single transformer and three-phase systems.
- b) Mid-phase grounding effectively controls, to safe levels, the transient overvoltages to ground.
- c) These diverse loads can be served from a single service.

The disadvantages are as follows:

- 1) The shock hazard of the high phase leg to ground is 208 V, which is 1.73 times the voltage of a neutral grounded 240 V system. Since this voltage can appear across a single pole of a breaker, 277 V rated breakers may be required.
- 2) There must be positive identification of the conductor with the highest voltage to ground to avoid connecting 120 V loads to that conductor.
- 3) The fault currents on the single-phase system may be higher than normally expected for the size of the system, possibly requiring higher rated panelboards.

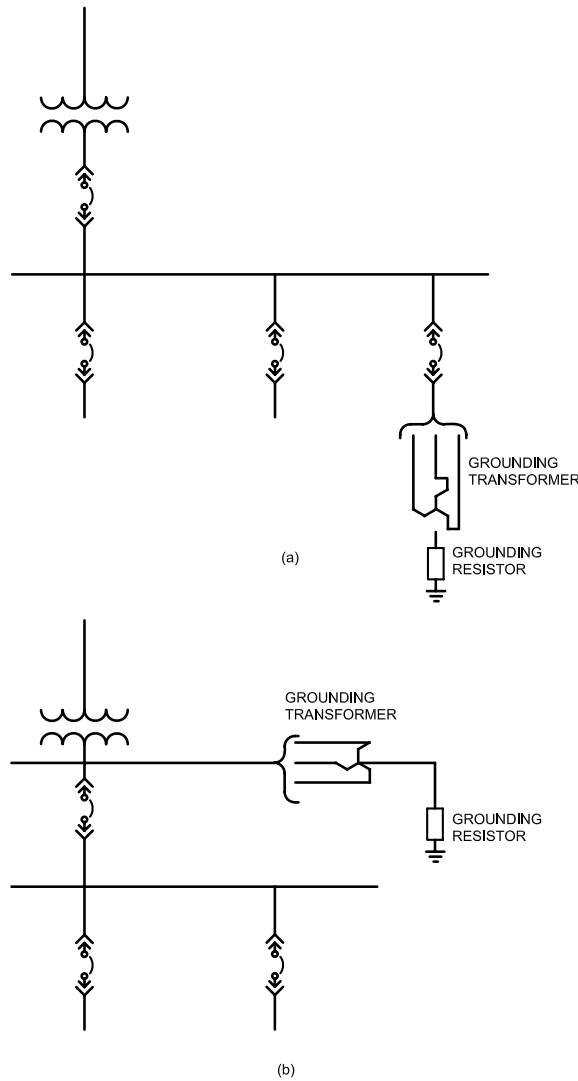

Figure 1-17—Connection of grounding transformers in delta connected or ungrounded power system to obtain neutral for system grounding: (a) circuit feeder breaker, (b) connected between main transformer and main switch gear

1.6 Location of system grounding points

1.6.1 Selection

Each system as described in this chapter is characterized by its isolation from adjacent grounding systems. The isolation is provided by transformer primary and secondary windings. The NEC defines such a system as “separately derived.” A separately derived system is one “whose power is derived from a generator, transformer, or converter windings and that has no direct electrical connection, including a solidly connected grounded circuit conductor, to supply conductors originating in another system.” Therefore, the new system created by a transformer or generator requires the establishment of a new system ground if it is required or desired that this system be grounded. See Figure 1-4 for an example of grounding each separately derived system. The system ground point should always be at the power source as required or permitted by the NEC, including exceptions for multi-source systems.

1.6.2 Transformer configurations

There are two requirements that must be met for a transformer to provide a system ground. The first requirement is fairly intuitive; the transformer winding at the voltage where a ground is desired must be connected in wye (sometimes referred to as *star* in European practice). The wye is essential to provide a neutral point that can be connected to earth; a delta winding does not present a neutral point and therefore there is no electrical connection that could be connected to earth for the purpose of establishing a ground reference for the system. Alternatively, transformers with windings connected in the interconnected star or *zigzag* configuration also provide a neutral point that can be grounded.

The second requirement is a bit more involved. Table 1-1 lists a number of options for the mode of system grounding; in order for these options to exist, the impedance of the transformer to ground-fault current must be significantly lower than the impedance of the connection between the neutral and earth such that this neutral impedance governs the selection of grounding mode. The *Electrical Transmission and Distribution Reference Book* provides a good theoretical background for this statement. Essentially, however, this requirement translates into a requirement that the transformer contain a second winding that is connected in delta. Thus, a transformer that is intended to provide a system ground must provide a wye-connected winding at the voltage of the system to be grounded, and must also contain a delta winding. The most common configuration that meets this requirement in industrial and commercial applications is a transformer that has a delta-connected primary winding and a wye-connected secondary winding.

Wye-wye transformers alone cannot be used to ground industrial and commercial power systems. In special cases it is possible to use wye-wye transformers that are equipped with delta-connected tertiary windings to provide system grounding. This arrangement can be designed for low-resistance grounding as well as effective grounding. It is also possible to use wye-connected autotransformers provided they also have a delta-connected tertiary winding, although this is a relatively uncommon practice and should only be used to provide effective (solid) grounding—applying a neutral grounding resistor between

ground and the neutral of an autotransformer can lead to undesirable neutral voltage excursions.

It is also a relatively common practice to use wye-wye transformers with special five-leg magnetic cores to serve commercial applications on effectively grounded (utility) distribution systems. This connection is chosen to address concerns with ferroresonance that come about because of single-phase switching (it is a common practice that utility distribution systems use single-point load-break switching devices, typically hook-stick operated), and this connection minimizes concerns with ferroresonance that would otherwise be present in that situation. But rather than provide system grounding itself, what the five-leg core wye-wye transformer does is to provide a continuous path for ground-fault currents from the primary distribution system into the commercial load on the secondary. Therefore, the system ground is actually established by the transformer that supplies the host distribution system. This practice therefore results in the commercial system also being effectively grounded.

1.6.3 Delta-wye transformer

In a delta-wye connected transformer, with the load-side neutral grounded, zero-sequence components of current can flow in the secondary wye-connected windings due to a ground fault. Zero-sequence current is then induced into the primary windings of the transformer and circulates in the delta connection. Positive and negative-sequence currents pass through the transformer combining to produce high current in two of the primary phase conductors. A ground fault on the secondary of the delta-wye connected transformer appears as a line-to-line fault on the primary. See Figure 1-18.

If the neutral of the wye-connected windings is not grounded, then zero-sequence current cannot flow and the system becomes ungrounded.

Zero-sequence components of current can flow through a wye-wye connected transformer if a neutral path exists on both sides of the transformer. An example is shown in Figure 1-20 where a delta-wye connected transformer, T_1 , supplies power to a wye-wye connected transformer, T_2 . A fault on the load side of T_2 produces zero-sequence current, which flows in the primary and secondary windings of that transformer. Zero-sequence current is permitted to flow in the primary of T_2 because a path exists in the delta-wye connected transformer T_1 . Disconnecting any of transformer neutrals, on either T_1 or T_2 , would prevent the flow of zero-sequence current in both transformers, except as allowed by magnetizing reactance.

Depending upon the connections to the transformer, the use of a wye-wye transformer can result in a single system, or its load side may be a separately derived system. Figure 1-19 and Figure 1-20 show a single system, whereas Figure 1-21 shows a separately derived system.

	SYMBOLS	CONNECTION DIAGRAMS	ZERO-SEQUENCE EQUIVALENT CIRCUITS
(a)			
(b)			
(c)			
(d)			

Figure 1-18—Zero-sequence impedance of different transformer configurations

NOTE—In Figure 1-18, configurations a) and c) permit the flow of zero-sequence current; b) and d) do not.³

1.6.4 Wye-wye transformers

A wye-wye transformer, T_2 , is shown in Figure 1-20 with the primary and secondary neutrals interconnected and grounded. This transformer configuration is used on solidly grounded utility distribution systems, particularly underground systems, to prevent ferroresonance when the supply switches can be operated one pole at a time. The utilities

³Notes in text, tables, and figures are given for information only and do not contain requirements needed to implement the standard.

ground the primary neutral point to minimize the neutral-to-earth voltage throughout the length of the distribution line and by default on underground systems using bare concentric neutral cables. They ground the secondary neutral to provide an effectively grounded low-voltage service. Note that this multiple grounding of the primary at each transformer is not essential to prevent ferroresonance or provide secondary grounding as long as the fourth conductor is brought to the primary neutral of the transformer. The neutral-to-transformer case and ground connection minimizes secondary neutral-to-ground voltage during a fault between primary and transformer case.

In an industrial distribution system, the physical length of the circuit will usually be short enough so that excessive neutral-to-ground voltages will not be present even if there is no ground at the wye-wye transformer common neutral terminals, as shown in Figure 1-19. The NEC normally prohibits grounding of the neutral on the load side of the service disconnect, but allows multigrounding of the neutral of an outdoor overhead line or direct burial cable with bare neutral if the circuit voltage is over 1000 V.

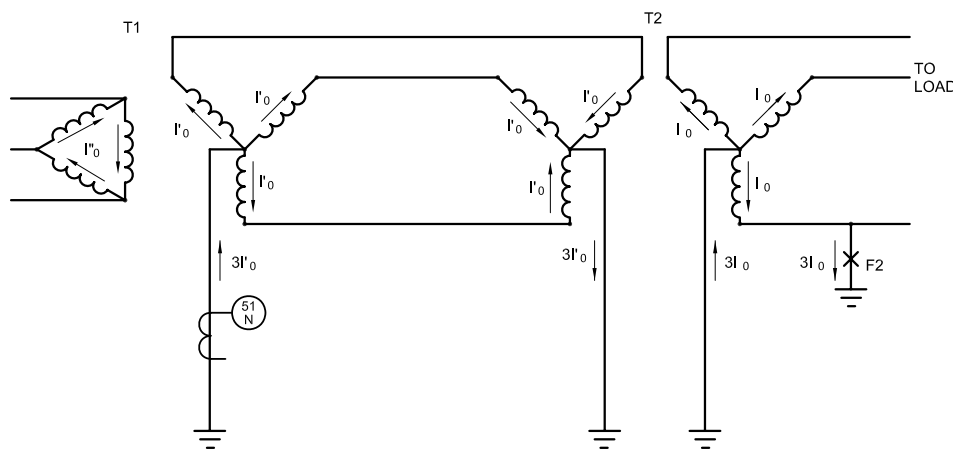

Figure 1-19—Transformer connections illustrating the flow of zero-sequence current resulting from a line to ground fault

As shown in Figure 1-19, with a continuous connection from the source neutral to the primary and secondary neutrals of the wye-wye transformer, the output of the transformer would not constitute a separately derived system as defined in the NEC. If the neutral is grounded at the source, T_1 , the output of the wye-wye transformer will be a continuation of the grounded system, though at the secondary voltage of the transformer. A fault, F_2 , on the load side of the wye-wye connected transformer, T_2 , will produce zero-sequence components of current in its primary windings. This zero-sequence current will flow back to the secondary neutral terminal of source transformer, T_1 . However, this current flowing through 51G cannot determine whether the fault is located before or after the wye-wye transformer, nor can residual or zero-sequence ground detection schemes on the output of T_1 . The main benefit of this transformer connection is to utilize the standard wye-wye transformer that contains an internal primary-to-secondary neutral connection suitable for utility practice as shown in Figure 1-20.

The circuit supplied by the wye-wye connected transformer shown in Figure 1-21 can be considered a separately derived system, since there are no direct metallic connections between the primary and secondary of the transformer. Primary and secondary ground faults are separately measured and relayed. The secondary of the transformer will not be grounded unless a connection to earth is made. The secondary could be impedance grounded. Secondary neutral grounding will also require a connection from the neutral of the primary source to the primary neutral of the wye-wye transformer to supply zero-sequence current. Unlike the delta-wye transformer, the wye-wye transformer itself is not a source of zero-sequence current. Grounding can be achieved without a primary neutral connection if a phase of the secondary rather than the neutral is grounded, since no zero-sequence current is involved. The effect is then identical to corner grounding of a delta-delta transformer.

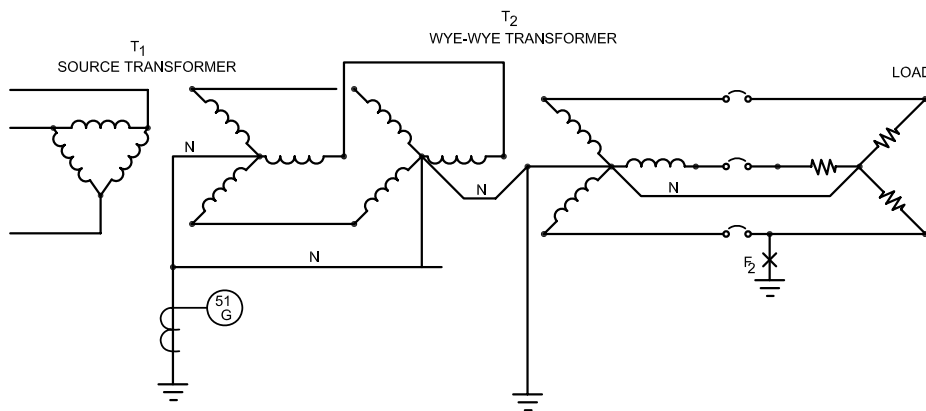

Figure 1-20—Grounded wye-grounded wye transformer with multigrounded common neutral

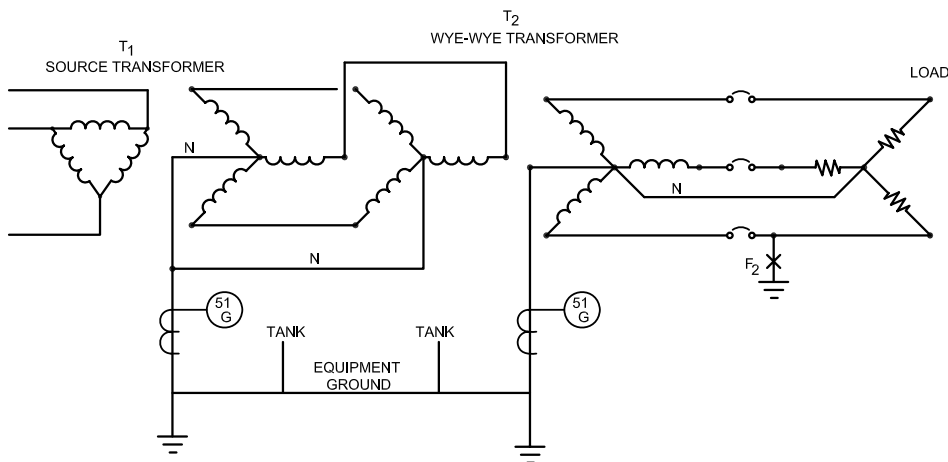

Figure 1-21—Grounded wye-grounded wye transformer with separately grounded neutrals

If a delta tertiary is added to a wye-wye transformer it will not be necessary to supply zero-sequence current from the primary source, since the tertiary will act as a source of zero-sequence current.

Thus, the wye-wye transformer can be considered a part of a single multi-voltage system if the neutrals are interconnected or can be considered to create a separate system if they are not. The symmetry of the wye-wye allows it to provide grounding for its load-side system even though the source and load side may be interchanged at any time.

1.6.5 Single power source

When a system has only one source of power (generator or transformer), grounding may be accomplished by connecting the source neutral to earth either directly or through a neutral impedance (Figure 1-22). Provision of a switch or circuit breaker to open the neutral circuit is not recommended. It is not desirable to operate the system ungrounded by having the ground connection open while the generator or transformer is in service.

In the event that some means of disconnecting the ground connection is required for measurement, testing, or repair, a disconnecting link should be used and only opened when the system is de-energized.

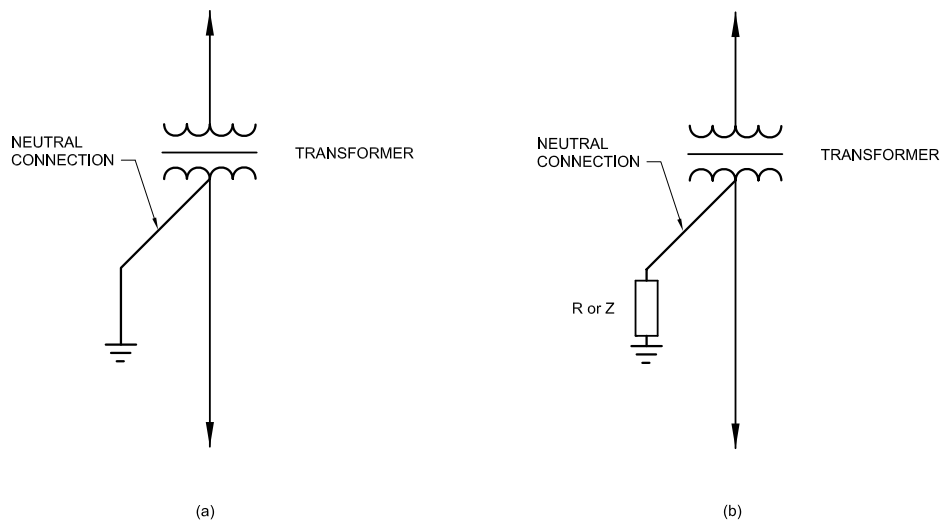

Figure 1-22—Grounding for systems with one source of power: (a) solidly grounded, (b) *R* or *Z* grounded.

1.6.6 Multiple power sources

For installation of interconnected multiple power sources (i.e., generators or power transformers), operated in parallel, system grounding can be accomplished using one of the two following methods:

- a) Each source grounded, with or without impedance (Figure 1-23).

- b) Each source neutral connected to a common neutral bus, which is then grounded, with or without impedance (Figure 1-24).

For solidly grounded systems, with multiple sources, where all sources must be solidly grounded, it is acceptable to separately ground each power source as shown in part a) of Figure 1-23 unless third harmonics are present or if it results in exceeding the fault capability of the generators. Levels of fault current in systems where generators are paralleled with transformer sources on a four-wire basis must be calculated using symmetrical component sequence values for the sources appropriately combined in the system (see Nichols). Commercial computer programs are now available that will calculate branch currents for unbalanced faults in systems with both utility and generator sources. There can be a significant increase in the total system ground-fault current as compared to the sum of the fault current available from sources when not in a combined system, while the increase in generator currents can be proportionally even greater. Refer to 1.7.3.2. Where sources are in close proximity, or where the system is four wire, the common neutral or ground bus as shown in part a) of Figure 1-24 should be used. In a four-wire system the sources would not be considered as separately derived.

If the power sources are not in close proximity, common ground point is not recommended. The impedance in the neutral bus connection may become large enough to prevent effectively grounding the neutral of the source at the remote location. The interconnection may inadvertently become open, allowing the transformer to operate ungrounded.

For impedance grounded systems it is acceptable to separately connect each neutral to ground through an individual impedance [part b) of Figure 1-23]. Each impedance rating should allow sufficient current to satisfy the criteria for the grounding system being used.

Individual neutral switching devices (automatic or manual) are not recommended, since incorrect operation may allow a power source to operate ungrounded.

System relaying is more complex when there are multiple ground-fault sources. The fault current sensed by the feeder is variable, depending on the number of ground-fault current sources that are connected at the time of the fault.

When individual source impedances are used for low- or high-resistance grounding, circulation of third harmonic currents between paralleled generators is usually not a problem since the impedance limits the circulating current to tolerable values. When the total ground-fault current from several individual impedances exceeds about 1000 A, a common ground point and single impedance should be considered to provide a single acceptable value of ground-fault current [part b) of Figure 1-24]. The advantage of this connection is that the maximum fault current is known, and selective relaying can be used to open tie breakers and selectively isolate the faulted bus.

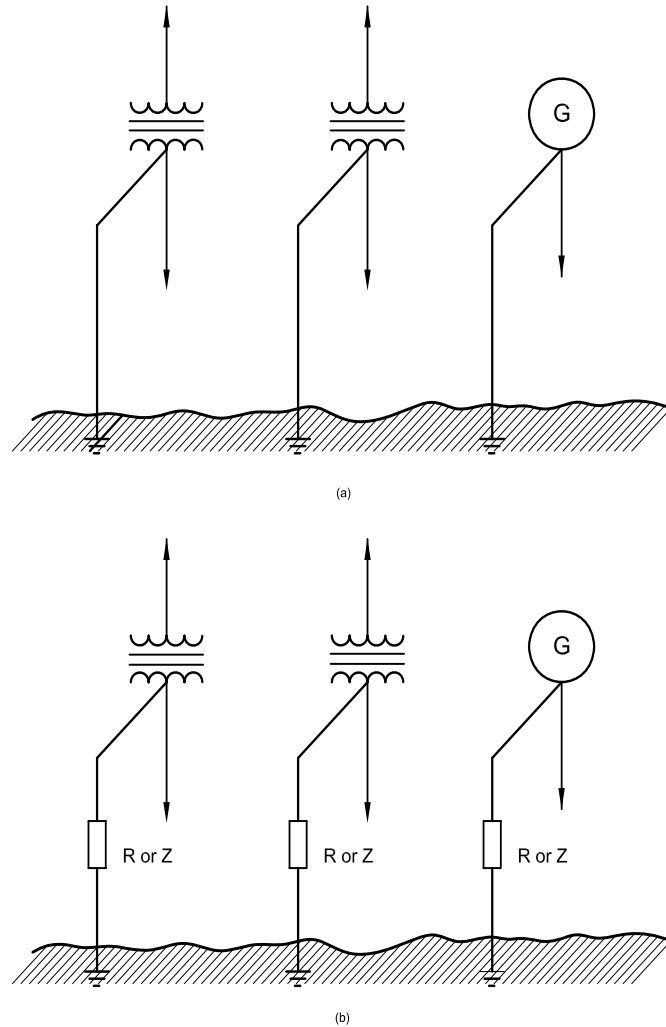

**Figure 1-23—Grounding for systems with multiple power sources
(Method 1): (a) solidly grounded, (b) R or Z grounded**

The primary purpose of neutral disconnecting devices in impedance grounded systems, as shown in part b) of Figure 1-24, is to isolate the generator or transformer neutral from the neutral bus when the source is taken out of service, because the neutral bus is energized during ground faults. A generator or transformer disconnected from the power bus, but with an unbroken connection of its neutral to the neutral bus, would have all of its terminals elevated with respect to ground during a ground fault. Disconnecting devices should be metal enclosed and interlocked in such a manner as to prevent their operation except when the transformer primary and secondary switches or generator main and field circuit breakers are open. On low-voltage systems the use of four-pole breakers may provide adequate interlocking. In this case line-to-neutral voltage should not be used for synchronizing.

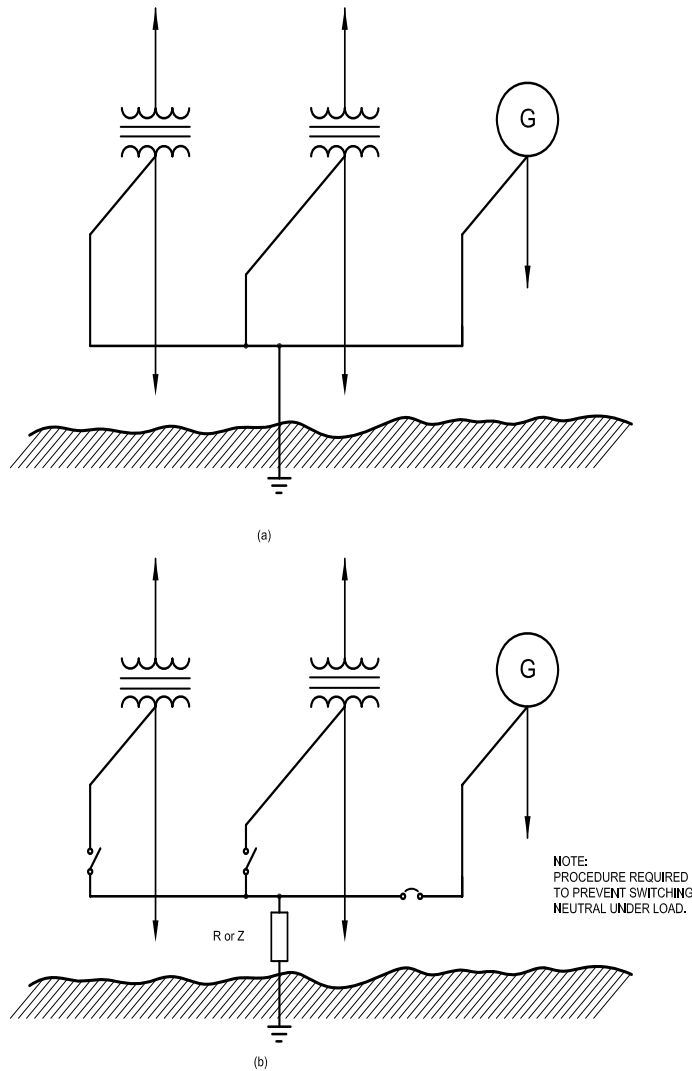

Figure 1-24—Grounding for systems with multiple power sources (Method 2): (a) solidly grounded, (b) R or Z grounded

In the case of multiple transformers, all neutral isolating devices may be normally closed because the presence of delta-connected windings (which are nearly always present on at least one side of each transformer) minimizes the circulation of harmonic current between transformers. Generators that are designed to suppress zero-sequence harmonics, usually by the use of a two-thirds pitch winding, will have negligible circulating currents when operated in parallel; therefore, it is often found practical to operate these types of generators with the neutral disconnect device closed. This simplifies the operating procedure and increases assurance that the system will be grounded at all times, because interlocking methods can be used.

It is sometimes desirable to operate with only one generator neutral disconnecting device closed at a time to eliminate any circulating harmonic or zero-sequence currents. In addition, this method provides control over the maximum ground-fault current and simplifies ground relaying. When the generator whose neutral is grounded is to be shut down, another generator is grounded by means of its neutral disconnecting device before the main and neutral disconnecting device of the first one are opened. This method has some inherent safety considerations that must be recognized and addressed in order to ensure continual safe operation. The procedures required to permit only one disconnecting device to be closed with multiple sources generally do not permit the use of conventional interlocking methods to ensure that at least one neutral disconnecting device will be closed. Therefore, this method should only be used where strict supervision of operating procedures is assured.

1.6.7 Grounding locations specified by the NEC

The following locations for ground connections are required, or permitted, by the NEC for the most common types of power system grounding. This is not intended to be a complete listing of code requirements, and the current edition of the NEC should be consulted for details or recent changes as well as to determine whether grounding is required or prohibited. The purpose of this subclause is to call attention to location requirements and not to interpret the requirements, since that is the province of the cognizant enforcing authorities.

On service-supplied systems of 50 V to 1000 V, system grounding, when required or elected, should be made at the service entrance, between the load end of the service drop or lateral and the neutral landing point. If the service is supplied from a transformer external to the building one additional grounding point is required external to the building. If a grounded conductor extends past the service entrance switch, it should have no further grounds on this extension except as noted by the various exceptions in the NEC to this requirement, as follows.

Where dual services feed a double-ended bus, a single ground at the center point of the neutral bus is allowed to replace those previously listed.

If more than one building is fed from a single service there should be a system grounding connection made at the entrance to each building. However, if an EGC is run with the load conductors, this ground connection can be eliminated so as to avoid elevating non-current-carrying enclosures above ground potential due to load drop in the neutral conductor.

Grounding connections should not be located or connected so as to cause objectionable currents in grounding conductors or grounding paths.

Separately derived circuits, if required or elected to have a system ground, should be grounded between the source and the first disconnecting device. System grounding connections downstream of the disconnecting device have the same rules as for service-supplied circuits.

The point of grounding for systems shall be the neutral or common conductor where one exists; otherwise the point shall be a phase conductor.

On systems over 1000 V, a transformer-derived neutral may also be used as the attachment point for a system ground. This method is not mentioned for effective grounding of low-voltage systems.

High-voltage and medium-voltage systems may also have multiple neutral grounds where the conductors are overhead outdoors or where they are directly buried with a bare neutral conductor.

1.7 Grounding of industrial and commercial generators

1.7.1 Industrial and commercial generator characteristics

Generators have several characteristics that are significantly different from transformers, the other common source of power. As compared to the transformer, the generator has little ability to withstand the heating effects or mechanical forces of short circuits. The generator may be required by standards to withstand a less than 10-per-unit short circuit, and the imposition of higher currents is defined as unusual service by the National Electrical Manufacturers Association (NEMA) MG 1, whereas a transformer may be required to withstand a 25 per-unit current. The generator may be capable of withstanding less than 25% of the heating effect of this current as compared to the transformer. If the current is unbalanced, this capability may be reduced to less than 10% of the transformer capability (see NEMA MG 1; Nichols).

Unlike the transformer, the three sequence reactances of a generator are not equal. The zero-sequence reactance has the lowest value, and the positive-sequence reactance varies as a function of time. Thus, a generator will usually have higher initial ground-fault current than a three-phase fault current if the generator has a solidly grounded neutral. According to NEMA, the generator is required to withstand only the three-phase current level unless it is otherwise specified (see NEMA MG 1). Also, NEMA states that the negative-sequence current thermal withstand limit is a product of time in seconds and the square of per-unit negative-sequence current (I_2^2t) equaling 40 (see NEMA MG 1). With a solidly grounded neutral, the steady-state ground-fault current will be about eight times that of full-load current, while the steady-state three-phase fault current is three times full-load current; but, because of the negative-sequence content of the ground-fault current, the generator has less thermal withstand capability than it would for a three-phase fault.

Generators produce slightly nonsinusoidal voltages because of saturation and imperfect winding and flux distribution (see Woodbury). Industrial generators therefore produce odd harmonic voltages, with the third harmonic voltage being as much as 10%. These harmonic voltages can cause heating from circulating currents in a closed loop. This is one reason why most industrial generators have their internal windings connected in wye rather than delta. The third harmonic voltages produced in the generator's windings are in phase and additive. This would cause third harmonic current to circulate within the delta-connected windings, as shown in Figure 1-25. The circulating current would create

additional heating within the generator thereby reducing some of its thermal capacity. Generators that operate in a delta connection allow for this in their design.

If the generator windings are designed with a two-thirds pitch, the third harmonic voltage can be suppressed (see Baker), but the zero-sequence impedance will be lowered increasing the ground-fault current.

A grounded generator connected to a delta-wye transformer is shown in Figure 1-26. Any third harmonic voltage, V_3 , produced by the generator would be impressed on the primary of the transformer. Since the third harmonic voltages are in phase, the voltage difference across each winding of the transformer's delta will equal zero and no third harmonic, or multiples of the third harmonic, current can be expected to flow.

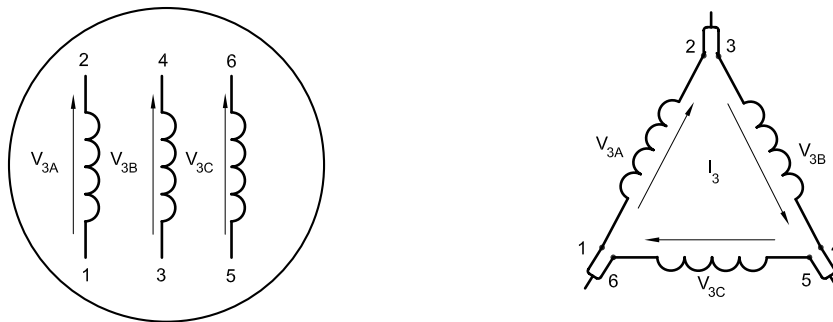

Figure 1-25—Circulation of third harmonic current in a delta-connected generator

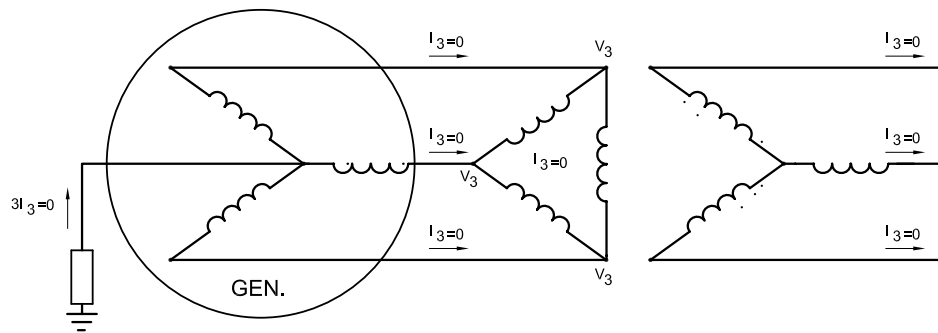

Figure 1-26—Analysis of third harmonic current (no zero-sequence loop)

Any current flowing as a result of a line-to-ground fault on the secondary side of the transformer will appear, as shown in Figure 1-27, as a line-to-line fault at the generator output. This type of fault is the most damaging to the generator because of its negative-sequence content. There will be no zero-sequence current flow in the generator even though the generator is grounded. Zero-sequence current will circulate in the delta winding of this transformer.

The physical limitations imposed by generator construction results in less available insulation thickness, with a resulting reduction in voltage-impulse withstand as compared to nonrotating electrical equipment. Thus, special attention should be given to limiting voltage to ground by the grounding of generator neutrals.

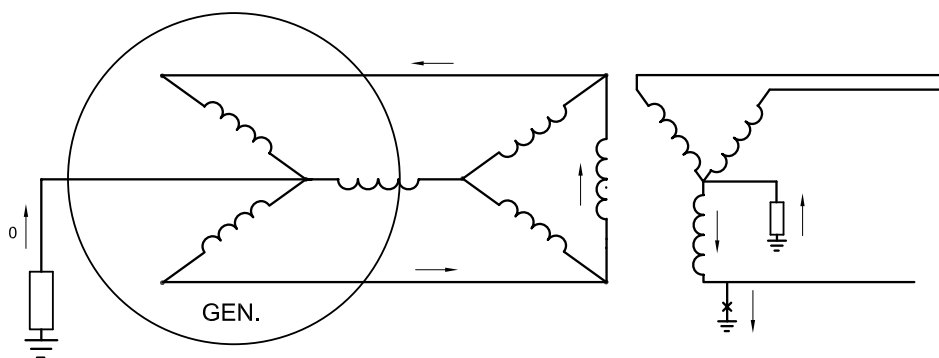

Figure 1-27—Zero-sequence currents during a wye side fault

Internal ground faults in solidly grounded generators can produce large fault currents. These currents can damage the laminated core, adding significantly to the time and cost of repair. Such currents persist until the generator voltage decays, since they are not capable of being interrupted by the generator circuit breaker (see McFadden). Both magnitude and duration of these currents should be limited whenever possible.

NOTE—One per unit is equal to generator-rated current.

1.7.2 Single unparalleled generator

This configuration may offer the most options for grounding. The distribution system may be particularly designed for flexibility in applying grounding by having only three-wire loads connected directly to the generator or even having only a single transformer connected to the generator (unit bank). Thus the design may employ high-resistance grounding to minimize damage from internal ground faults, or low-resistance grounding if needed to operate selective ground relays. In either case the ground-current level should be substantially less than the phase-current fault levels.

The generator may also be applied to a four-wire load without transformation. If the generator is rated for solidly grounded service, the neutral may be connected directly to

the grounded circuit conductor. If a standard generator is used, a reactor should be connected between neutral and the grounded circuit conductor so as to limit the momentary ground-fault current to no more than the momentary three-phase fault current (see Beeman; NEMA MG 1). When $3i_0 = i''_d$ the value of this neutral reactor, X_N , should be as shown in Equation (1.1):

$$X_N = 1/3(2X''_d - X_2 - X_0) \quad (1.1)$$

where

$$3i_0 = \text{Ground-fault current} = 3V_{in}/(X''_d + X_2 + X_0 + 3X_N)$$

$$i''_d = \text{Three-phase subtransient fault current} = V_{in}/X''_d$$

$$X''_d = \text{Generator subtransient reactance}$$

$$X_2 = \text{Generator negative-sequence reactance}$$

$$X_0 = \text{Generator zero-sequence reactance}$$

$$V_{in} = \text{Phase to neutral voltage}$$

Note that a resistor should not be used for this purpose, since its impedance is in quadrature with the machine reactance and thus would require a much larger value of resistance than reactance. This resistance would incur large losses from the flow of either fault or load current. The zero-sequence load current would also produce an objectionable voltage drop, since the load is primarily resistive.

On the other hand, the neutral reactor will cause little voltage drop to be produced by in-phase zero-sequence load current. The total zero-sequence current will be a small value because the generator has limited unbalanced current capacity. The continuous negative-sequence current capability of generators covered in ANSI C50 standards is 8% or 10%. For salient-pole generators covered under NEMA MG 1, the limit is 10% at full load. The use of the reactor between the generator neutral and the neutral circuit conductor does not affect the NEC requirement that the neutral circuit conductor be solidly grounded.

If generators are solidly grounded, the system's circuit breaker duty must be calculated at the higher ground-fault duty.

If the wye side of a delta-wye transformer is connected to a generator that is configured for four-wire service, the generator should be designed with a two-thirds pitch winding. This transformer will act as a short circuit to third harmonic currents, and without cancellation of third harmonic voltage, the resultant current may adversely affect ground-fault relaying and generator capacity.

1.7.3 Paralleled generators in an isolated system

This subclause covers only those generators that are paralleled to other generators on the same bus. Generators paralleled through transformers would be considered as paralleled to a separate source. (See Pillai et al.)

1.7.3.1 Circulating harmonic current

The considerations are similar to 1.7.1 except for the possible circulation of third harmonic current between solidly grounded generators if any of the generators do not have two-thirds pitch windings. If generators are of identical design, there will be no significant circulation of third harmonic current while the generators are being operated at identical power and reactive current outputs. If the generators are not of identical design, there will be a third harmonic circulating current. If identical generators are operated with unequal loading, there will be a third harmonic circulating current.

This is demonstrated in Figure 1-28, where two generators are shown solidly connected to a neutral bus. Due to differing electrical parameters and construction details, each generator produces a different amount of third harmonic voltage, e_{31} and e_{32} , at its terminals. As a result a third harmonic current circulates between the generators. The magnitude of this current depends on the third harmonic loop voltage, e_3 , and the third harmonic loop impedance, Z . Since the generators are solidly connected to the neutral bus, the third harmonic loop impedance can be small. The resulting circulating current produces additional heat in each generator. More important, the zero-sequence third harmonic current circulating through the loop may pick up ground relays causing false tripping of the generator circuit breakers (see McFadden).

Generators with two-thirds pitch windings have the minimum impedance to the flow of third harmonic currents generated elsewhere due to their low zero-sequence impedance.

High-resistance grounding of the generators will adequately limit these harmonic currents. Thus, it is attractive to use high-resistance grounding on the generators, as shown in Figure 1-29, even if there are load feeders directly connected to the generator bus, and to use low-resistance bus grounding to provide selective relaying on the load feeders. Low-resistance grounding of the generators at values not exceeding 25% of generator rating will normally suppress third harmonic current to adequate values even with dissimilar generators, but the variable ground-fault current available with multiple generators may pose a relay-coordination problem.

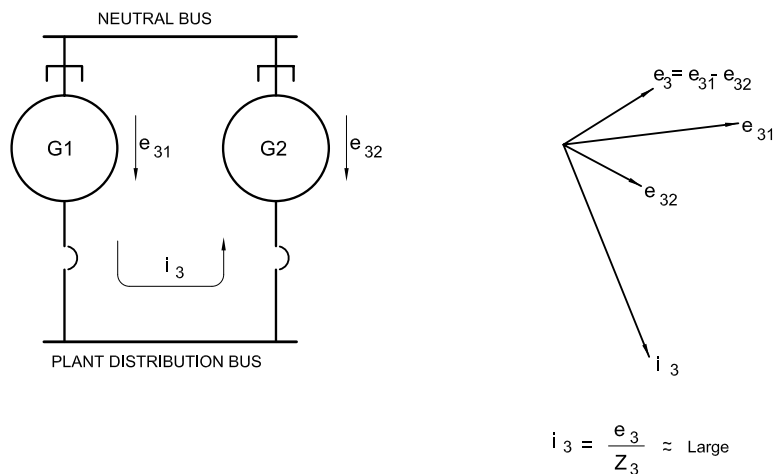

Figure 1-28—Two parallel generators solidly connected to a neutral bus

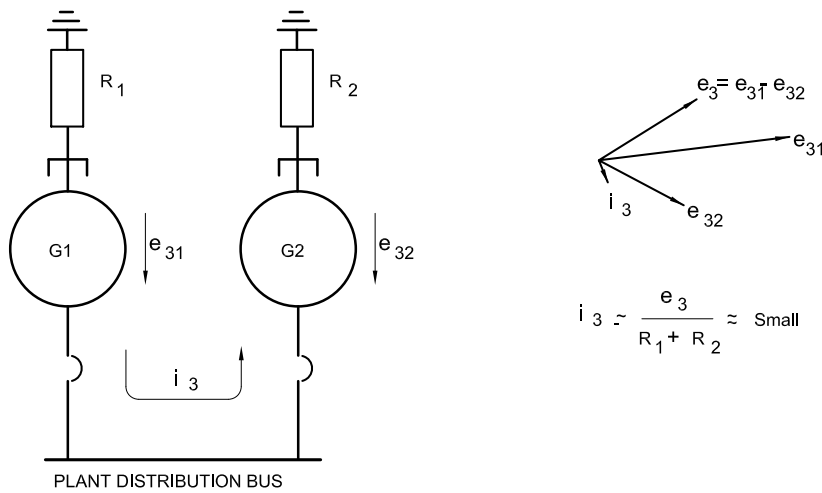

Figure 1-29—Two parallel generators with grounding resistors

1.7.3.2 Ground-fault limitations

NEMA MG 1 places a requirement on the design of synchronous generators that windings shall be braced to withstand the mechanical forces resulting from a bolted three-phase short circuit at the machine terminals. Generator phase currents to ground can actually exceed these three-phase values causing possible machine damage (see Woodbury). This can be illustrated [see Equation (1.2)] by considering a generator with typical per unit impedances of

$$X_1 = X_2 = 0.14 \text{ pu}, X_0 = 0.08 \text{ pu} \tag{1.2}$$

where X_1 , X_2 , and X_0 are the positive, negative, and zero-sequence reactances, respectively. The three-phase fault current, I_{3ph} , at the generator terminals, as a function of the line to neutral voltage is shown in Equation (1.3):

$$I_{3ph} = E_{LN}/X_1 = 1/0.14 = 7.14 \text{ pu} \tag{1.3}$$

If the generator neutral is solidly grounded, the line-to-ground fault current, I_{SLG} , at its terminals, as given by Equation (1.4):

$$I_{SLG} = 3E_{LN}/(X_1 + X_2 + X_0) = 3/(0.14 + 0.14 + 0.08) = 8.33 \text{ pu} \tag{1.4}$$

The ground-fault current is therefore $8.33/7.14 = 1.17$ times the required generator design capability. Since ground faults are more likely to occur than phase faults, they pose a greater potential threat to the system.

If two generators are connected in parallel as shown in Figure 1-30 and only one is solidly grounded, then the ground-fault current increases to 1.91 times three-phase fault current of

one generator. The current in the faulted phase of the grounded generator further increases to 1.27 times the required design value. Both can be seen by considering the phase A current at the fault, as shown in Equation (1.5):

$$I_1 = I_2 = I_0 = 1/(0.07 + 0.07 + 0.08) = 4.545 \text{ pu} \quad (1.5)$$

$$I_a = I_1 + I_2 + I_0 = 13.63 \text{ pu}$$

where I_1 , I_2 , and I_0 are the positive, negative, and zero-sequence components of the fault current.

In the grounded generator [see Equation (1.6)]:

$$I_0 = 4.545 \text{ pu} \quad (1.6)$$

$$I_1 = I_2 = 4.545/2 \text{ pu}$$

$$I_a = 4.545 + 2(4.545/2) = 9.09 \text{ pu}$$

and the ground-fault current is $13.63/7.14 = 1.91$ times the calculated three-phase fault current of one generator. The phase A current in the grounded generator is now $9.09/7.14 = 1.27$ times the three-phase faulted level of one generator.

The preceding example provides reasons for not solidly grounding generator neutrals. Where the neutrals are to be grounded, impedance should be added.

Where multiple generator are solidly grounded but have switches in the neutral, there has sometimes been the practice of grounding only one of the generators in parallel to limit ground-fault current duty or circulating third harmonic current. This will increase the fault-current duty in the grounded generator above that for which it would customarily be rated. A chart showing this difference appears in the *Electrical Transmission and Distribution Reference Book*. The ability to switch neutrals appears to invite operational errors that could affect integrity of grounding, allowing overvoltage on four-wire loads, which would result in failure to meet criteria for effective grounding or acceptable reactive grounding and thus would possibly violate the NEC.

1.7.4 Generators as unparallelled alternate sources

This category covers emergency and standby generators that are connected to the loads by transfer switches, which precludes paralleling with the normal source. With three-wire systems, the generators would be considered a separately derived source, since there would be no continuous connection through a system neutral. Generator grounding practices would be guided by 1.7.2 and 1.7.3.

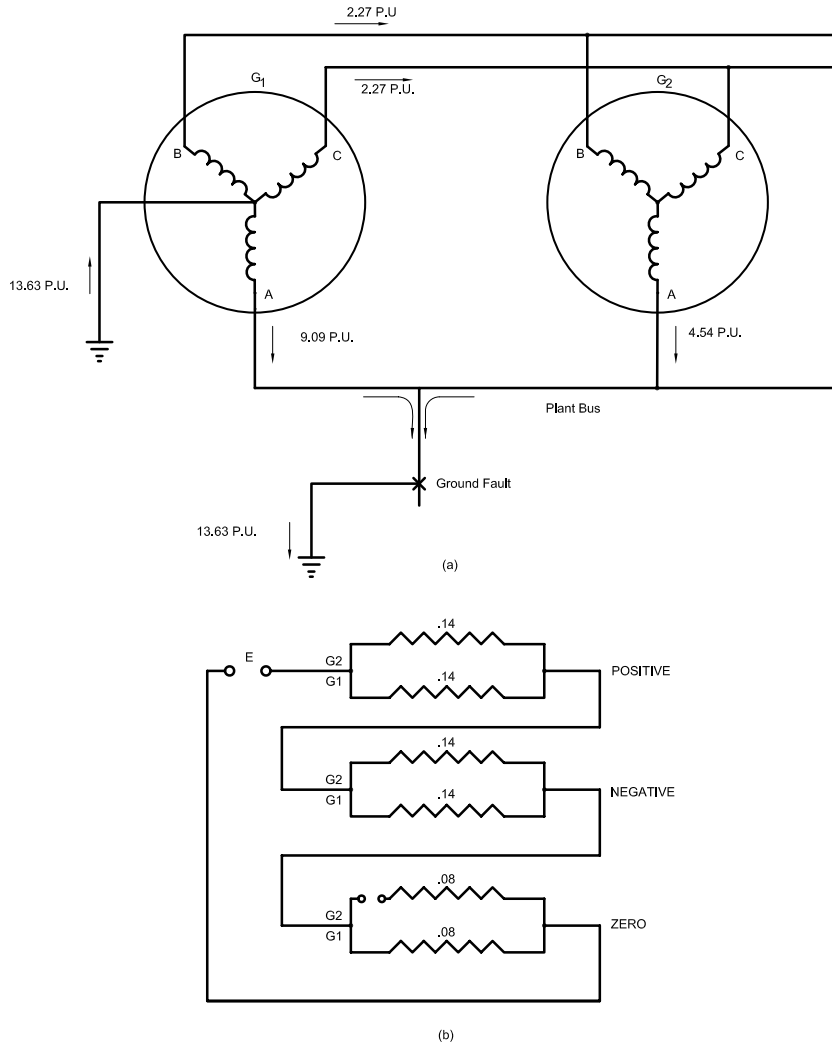

Figure 1-30—Ground fault on a system with two parallel generators

Where four-wire systems are involved, it has been shown in IEEE Std 446TM (*IEEE Orange Book*TM), Chapter 7, that objectionable currents can flow if a three-pole transfer switch is used. Whether or not the neutral is grounded at the generator as well as at the normal service, ground-fault relaying errors can occur. The NEC does not require neutral grounding at a generator when it has a common neutral with the grounded utility service neutral conductor. However, this connection scheme will not allow any repair or testing of the normal system, which involves disconnection from ground of the neutral conductor to the generator if the generator is operating. There is the hazard that workers performing such repair, or tests, may not be aware that the generator is operating. The use of a four-pole transfer switch can eliminate these problems and is recommended.

1.7.5 Generators paralleled with other sources

This category describes generators connected to transformers that are, or can be, connected to other power sources. While the primary consideration is the generator grounding, decisions can be affected by the necessity of providing the desired grounding on the other side of the transformer while other generating sources may be disconnected (see Pillai et al.).

The use of a delta-wye transformer, as shown in Figure 1-31, with the wye facing the generator offers the advantage of providing neutral grounding, solid or impedance, to the generator-fed bus when the generator is not connected. It has the disadvantage of not offering grounding to the system connected to the delta side of the transformer. Also, in the event that the transformer is removed from service, an alternate ground source would be needed. It does present a hazard if both the transformer and generator neutrals are solidly grounded (see Nichols).

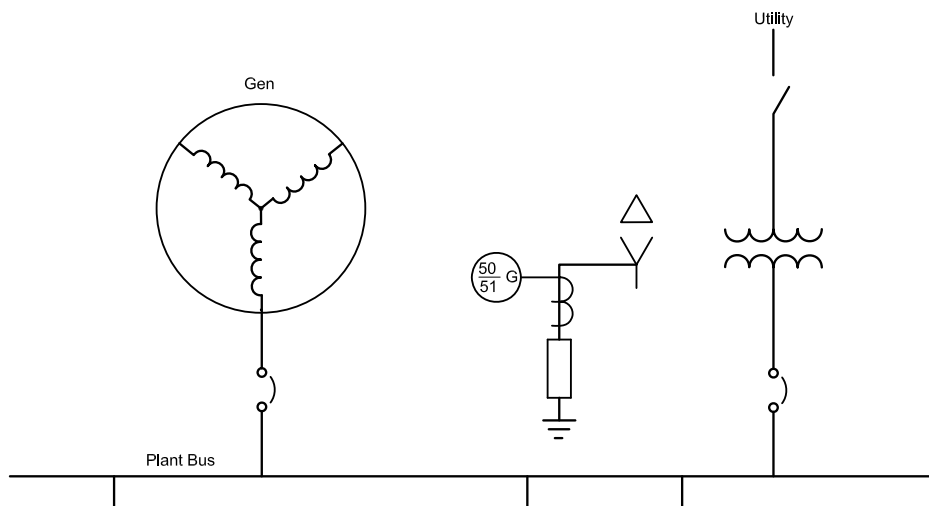

Figure 1-31—Generator in parallel with a transformer

The wye winding with a delta primary is a short circuit to any third harmonic current produced by the generator. The ground-fault duty on the bus will be greater than the arithmetical sum of the ground-fault currents supplied by the transformer and generator when each is connected to the bus independently. The ground-fault current in the generator will exceed that which would occur when the generator is not paralleled. The fault currents must be calculated using symmetrical component techniques as shown in Nichols, rather than simply using the sum of the admittances of the transformer and generator sources. A generator rated for grounded service not otherwise specified is normally rated for the ground-fault current flowing when not paralleled.

A generator neutral reactor can be used to limit the generator-fault duty to an acceptable value as calculated per Nichols, but may not limit any generated third harmonic current to

an acceptable value. Thus, suppression of third harmonic may be necessary to facilitate adequate ground-fault relaying.

If the delta of a delta-wye transformer is connected to the generator bus, as shown in Figure 1-32, neutral grounding is available on the wye side of the transformer. However, the generator bus will be ungrounded until such time as the generator is grounded or independent bus grounding is employed. Some type of grounding transformer (wye-delta or zigzag transformer) can be used to produce either effective or impedance grounding of the bus. If a grounding transformer is connected to the bus, the generator may be high-resistance grounded.

A wye-wye transformer as shown in Figure 1-21 can provide grounding to the side opposite the source, whichever side may have the source connected. The disadvantage is that the zero-sequence current must be provided by the source, so that the system grounding required on the other side of the transformer will dictate the type of generator grounding. If a delta tertiary is added to the transformer, this tertiary will supply the zero-sequence current so that the generator can be grounded without regard to system grounding requirements on the other side of the transformer.

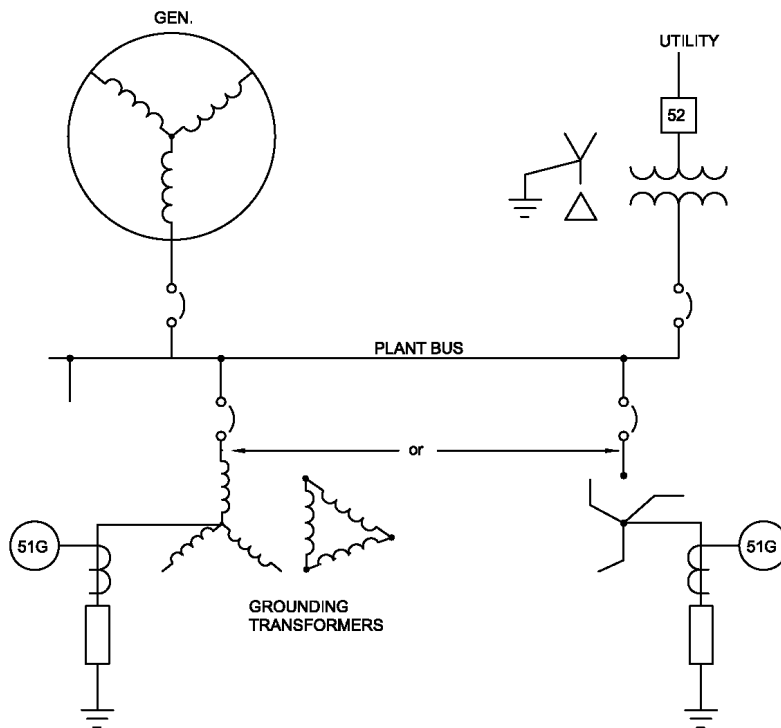

Figure 1-32—Use of grounding transformers in a distribution system

The methods of grounding are also described in IEEE Std C37.101™, which covers generator ground-fault protection as well. It should be noted that this standard was developed primarily for utility generators and does not contain some of the considerations for industrial applications.

1.8 Autotransformers

Occasionally autotransformers will be used to transform voltage, usually to reduce transformer cost, or perhaps to avoid creating a new grounding system. Unless the system grounding is suitable for the use of an autotransformer and the autotransformer is properly applied, its use may seriously reduce grounding and ground relaying effectiveness and expose equipment to a voltage-to-ground level higher than that for which it is designed.

The three-phase wye autotransformer with no delta tertiary has extremely high zero-sequence impedance if no connection is made to its neutral. Figure 1-33 shows that a ground fault at A' will cause the source line-to-ground voltage to be imposed across the A-A' section of the autotransformer. Should that section of the winding be able to support this voltage, then the voltage to ground at N, the neutral of the autotransformer, would rise in proportion to the turns ratio of A'-N to A-A', and B' and C' would have voltages to ground higher than B and C, the high-voltage level. The secondary line-to-line voltage can also be increased.

In normal practice, winding A-A' would not support the full voltage, but would instead saturate, thus passing a certain amount of zero-sequence current. In the process, it will create high-frequency components of voltage, at which frequency the winding can support a voltage proportional to that frequency. Thus, a very high voltage to ground could still exist at N.

Even if the secondary of the autotransformer is the higher voltage, it will still be overvoltage by a secondary line-to-ground fault as shown in Chapter 6 of Beeman. This reference also points out that overvoltages can also be caused by transient surges, such as from switching or lightning, being impressed across the section of winding between the primary and secondary connections.

Figure 1-34 shows that when a source to a step-down autotransformer is impedance grounded, a ground on the source side of the autotransformer can cause the voltage from B' and C' to ground to approach the line-to-line voltage of the source. If the autotransformer steps up the voltage, the voltage to ground on the lower voltage system will lie between that shown in Figure 1-35 and what might be achieved in Figure 1-36, depending upon the relation of the grounding impedance to the exciting impedance of the autotransformer.

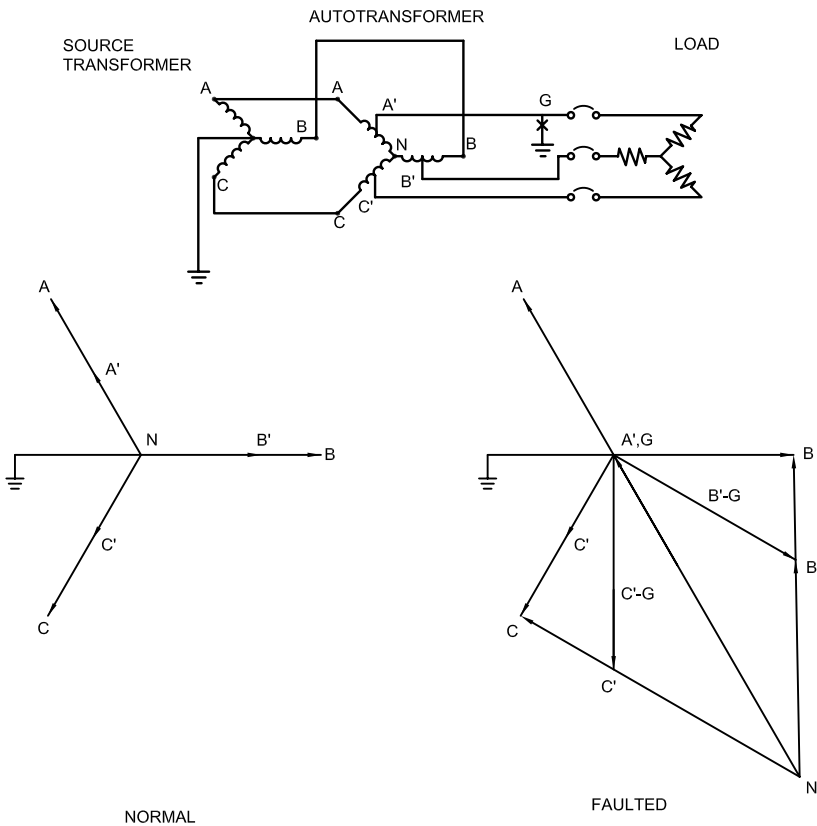

Figure 1-33—Ungrounded wye step-down autotransformer with load fault

Figure 1-36 shows that delta autotransformers do not offer a reduction in voltage to ground on the lower voltage system commensurate with the reduction in phase voltage, thus reducing the cost benefit of choosing the autotransformer rather than a full transformer. The open-delta version offers no reduction in maximum voltage to ground, but does result in an unbalanced voltage to ground that might be undesirable. In neither case do ground faults cause increased voltages to appear across the transformer windings, and line-to-ground voltage at either voltage will not exceed the higher line-to-line voltage. Should a full transformer be used in either case, it might be possible to reduce the class of insulation in the lower voltage system. Like most solidly grounded systems, a large ground-fault current will occur, limited primarily by transformer impedances. The actual voltage drops across the two transformers will have complex relationships depending upon the relative ratings and saturation characteristics of the two transformers. These voltage drops are not necessarily in phase.

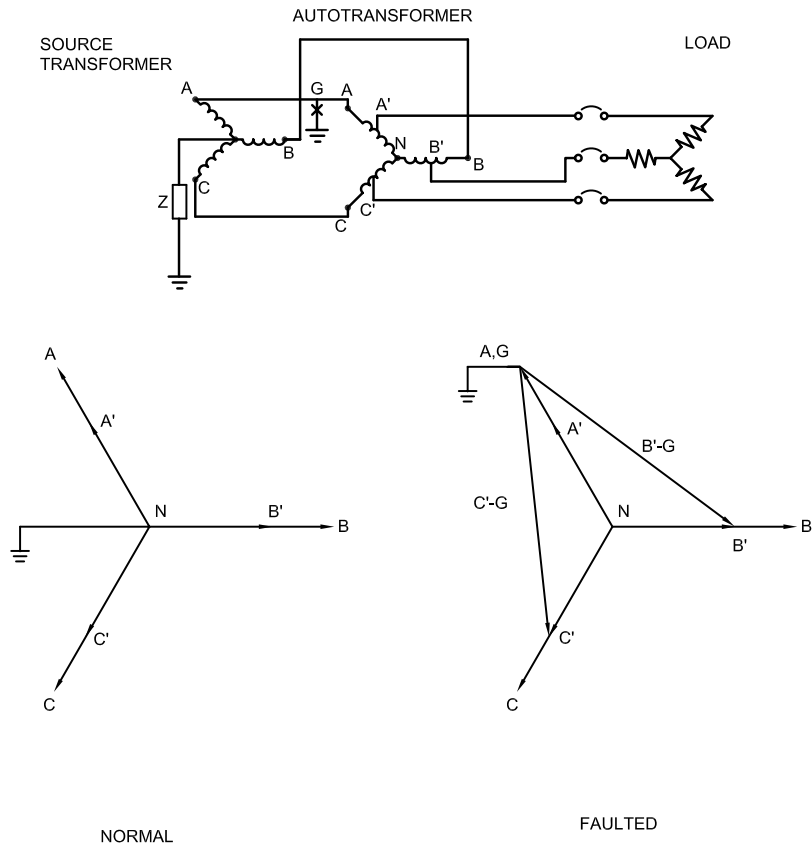

Figure 1-34—Ungrounded wye step-down autotransformer with primary fault

In all the preceding examples there is a safety hazard due to normal perceptions of the relation of maximum voltage to the normal voltage on a circuit. For this reason, the NEC has imposed restrictions as to how autotransformers can be used.

Figure 1-37 shows the correct configuration for using an autotransformer. There must be an effective connection between the neutral of the autotransformer and the neutral of the source transformer for flow of zero-sequence current. In an industrial installation where the NEC would apply, the connection must be made by extending the neutral of the source transformer. No ground connection must be made at the autotransformer to comply with the NEC. A circuit supplied by an autotransformer does not meet the criteria of a separately derived system.

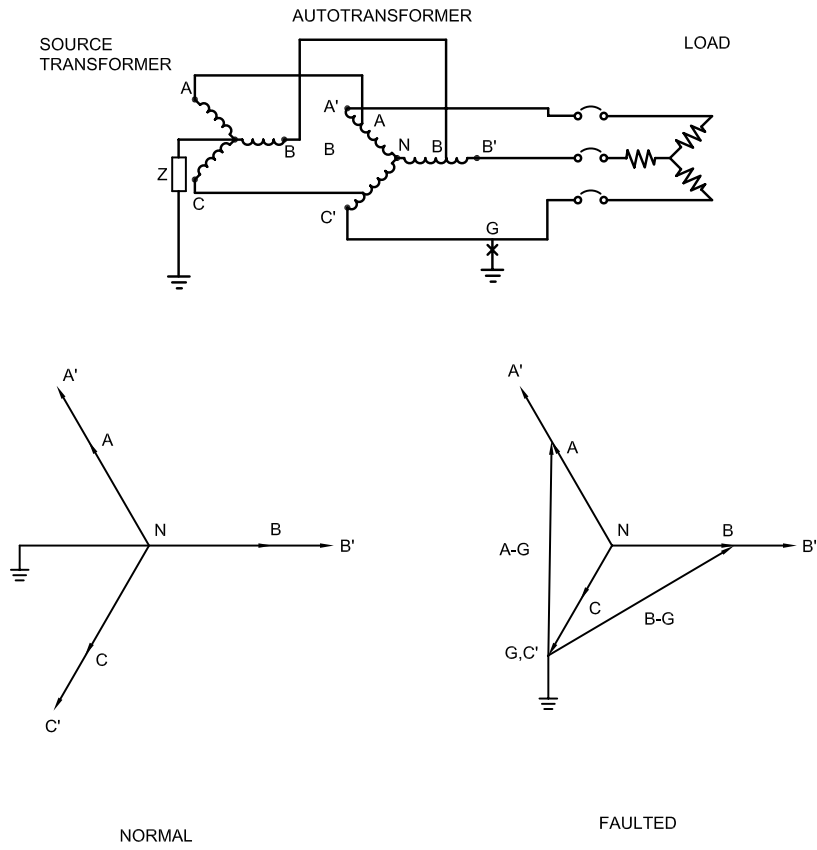
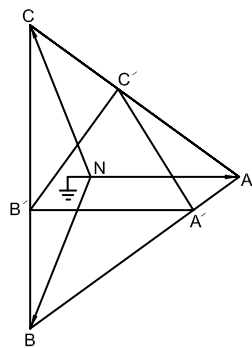
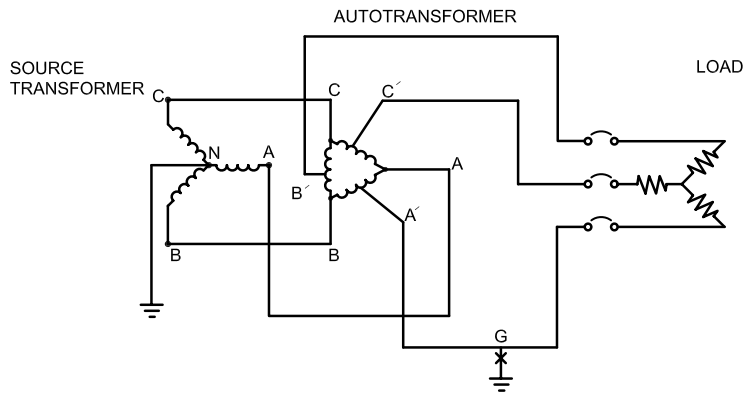
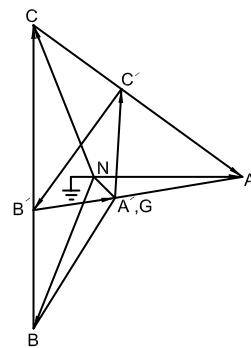

Figure 1-35—Ungrounded wye step-up autotransformer with load fault



NORMAL



FAULTED

Figure 1-36—Delta autotransformer with load fault

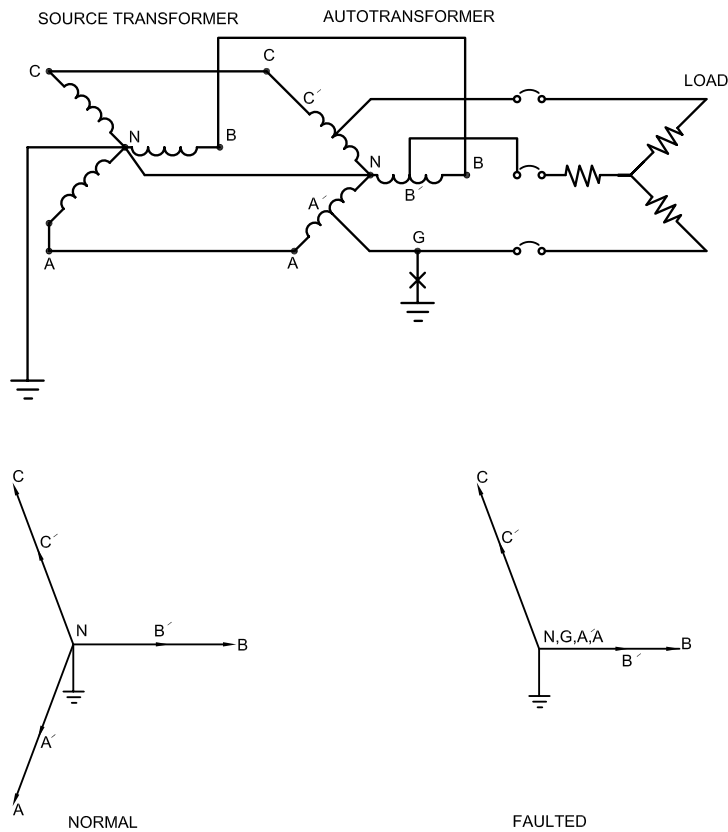

Figure 1-37—Wye autotransformer with grounded neutral, four-wire connection

1.9 System grounding for uninterruptible power systems

1.9.1 General

As with any electrical system, correct grounding of uninterruptible power supplies (UPS) is essential to the overall safety and performance of the system. In particular, personnel safety, equipment protection, and electronic performance can all be jeopardized by incorrect or ineffective grounding.

UPS units come in a variety of configurations (see “System Grounding for Uninterruptible Power Systems”). In typical UPS units, the UPS ac output is electrically isolated from the UPS ac input. However, most practical UPS systems also include one or more bypass arrangements, which, depending on the particular arrangement, makes the UPS system either a separately derived system or not. Three of the potential arrangements are shown in Figure 1-38, Figure 1-39, and Figure 1-40. In these figures, EGCs are shown

supplementing the conduit grounding of the enclosures as is recommended practice when supplying electronic equipment. Battery cabinets are shown, but racks of batteries may also be used with UPS systems. See IEEE Std 1100™ (*IEEE Emerald Book™*) for more information on dc grounding. The UPS are shown as single units but may consist of one or more parallel-connected modules, particularly for larger capacity or redundancy. More elaborate schemes than presented in the three examples may be encountered. Additional wraparound maintenance bypass switching schemes are often added to the basic UPS configurations to facilitate maintenance of the UPS unit while continuing to supply power to the load. For further discussion on UPS systems, see IEEE Std 446™ (*IEEE Orange Book™*) and IEEE Std 1100™.

1.9.2 Separately derived UPS system

Figure 1-38 depicts a conventional static UPS unit whose ac (inverter) output is electrically isolated from the main ac (rectifier) input. The static bypass input is supplied with a three-wire-plus-ground feed from a solidly grounded power system. All three phases of the UPS bypass input are switched by the UPS, and so there is no direct electrical connection between the UPS ac output and another grounded power system. In this configuration, the UPS ac output is a separately derived system. As such, the UPS ac output is grounded in accordance with NEC requirements for separately derived systems. The UPS output neutral is bonded to the EGC and a GEC is connected to the nearest effective grounding electrode. If the UPS output neutral is not correctly connected to the EGC and GEC, the UPS output will not be properly referenced to ground with the resulting uncontrolled voltages to ground. It should be noted that this configuration of UPS grounding, with a three-wire-plus-ground bypass feed, can only be used when the UPS does not serve line-to-neutral loads unless other provisions are made to derive the line-to-neutral voltages when operating the UPS in the bypass mode.

1.9.3 Nonseparately derived UPS system

Figure 1-39 depicts the same conventional static UPS unit shown in Figure 1-38 except that the bypass input is supplied with a four-wire plus ground feed from a solidly grounded power system. This configuration is often encountered when line-to-neutral loads are served directly from the UPS. In this configuration, the UPS output neutral is solidly connected to the grounded bypass neutral. Most UPS units do not switch the bypass and output neutral when the phases are switched. Therefore, the UPS output is not a separately derived system but rather a solidly grounded interconnected system. As such, the UPS neutral may not be connected to the EGC or a GEC. If the UPS output were mistakenly connected to the EGC or GEC, the bypass input power system would be grounded at more than one point. This is an NEC violation and it allows normal neutral currents to flow on the grounding system that can upset electronic equipment and confuse ground-fault protection.

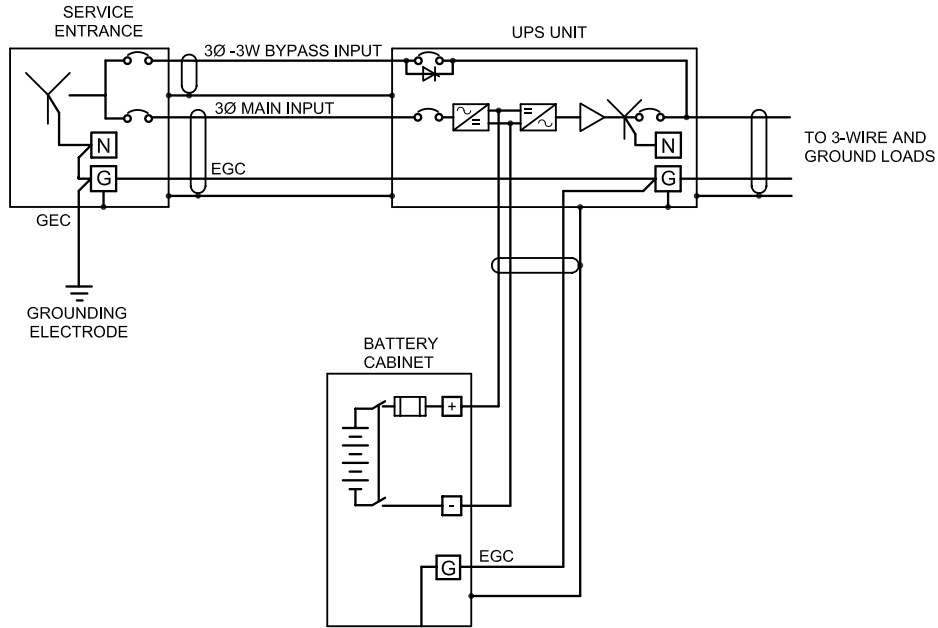

Figure 1-38—Separately derived UPS system

When the UPS is configured as a nonseparately derived system (a solidly grounded interconnected system), a ground fault on the output of the UPS must return to the UPS neutral by way of the upstream system (service entrance) neutral-to-ground bond and, as such, may trip upstream ground-fault protection devices. This confusion of the ground-fault protection devices is also described in IEEE Std 446 (*IEEE Orange Book*), Chapter 7, for the configuration of a three-pole transfer switch supplying four-wire loads.

1.9.4 Separately derived UPS system serving four-wire loads

Figure 1-40 depicts the same conventional static UPS unit serving four-wire loads as shown in Figure 1-39, except that the UPS bypass input is supplied from a bypass transformer that isolates the four-wire plus ground bypass feed to the UPS and allows the UPS system to be separately derived. This configuration is useful to provide power source grounding (neutral-to-ground bond) close to the loads, which is recommended for electronic loads. The neutral-to-ground bond can be located at the UPS output or at the bypass transformer, but not both.

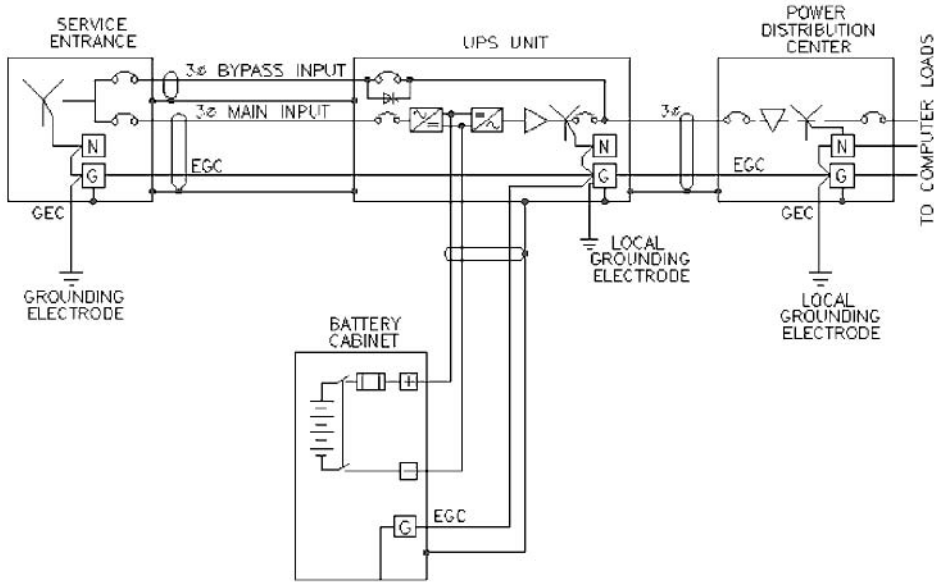

Figure 1-39—Nonseparately derived UPS system

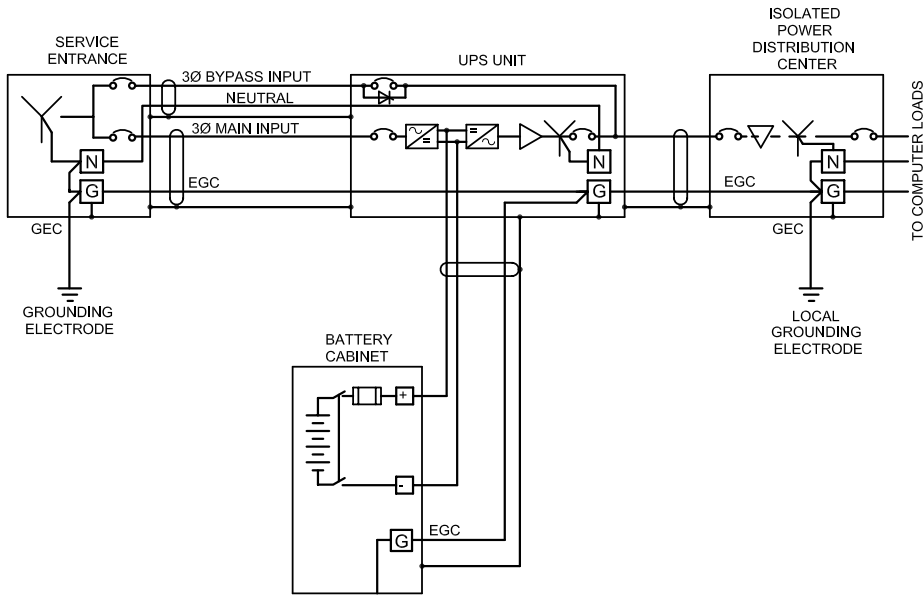

Figure 1-40—Separately derived UPS system serving four-wire plus ground loads

1.10 Portable mining equipment supply systems

The concept of protecting mine electrical equipment and personnel by suitable grounding has existed since electricity was first introduced into mines. As early as 1916, the U.S. Bureau of Mines recommended equipment frame grounding as a means of preventing electrical shock to miners working on or around electrical equipment (see Clark and Means). Adequate grounding has been a difficult problem for the mining industry, sometimes more complex and challenging than for other industries. Hazards associated with ground faults are amplified by the portable and mobile nature of these power systems, and system and equipment grounding are interrelated. A surface-mine machine can have a substantial power demand (e.g., 15 MW) at potentials up to 25 kV or greater. The power demand of an underground mining machine can exceed 1100 hp at potentials up to 4160 V. The portable equipment must be designed to permit personnel to approach (and touch) apparatus structures without risk of electric shock. This subclause will emphasize the grounding aspects of the supply system, whereas, Chapter 2 will cover related equipment-grounding information. Morley provides extensive details about both subjects.

A simplified arrangement of a mine power system is shown in Figure 1-41. Substations are employed to transform the incoming utility voltage to a distribution level. Mine distribution is almost always expanded radial, and overhead lines (surface mines) or cables (surface and underground mines) are used to supply switchhouses (portable switchgear) located near load concentrations. In typical underground mines, switchhouses are connected via portable cables to portable power centers, which supply lower voltage through trailing cables to the utilization equipment (e.g., continuous miners, long walls, load-haul-dump units). In surface mines, large utilization equipment, such as shovels and draglines, are often powered at the distribution voltage, and a trailing cable completes the power circuit from the switchhouse to the machine. (As with underground mines, portable substations or power centers are used when distribution and utilization levels are different.)

The recommended grounding technique for these portable or mobile equipment applications is a safety ground system that employs resistance grounding. Figure 1-41 illustrates the concept (overload and short-circuit protection are not shown for clarity of the grounding systems and associated protective relaying). The substation contains two separate ground beds (station ground, safety ground), maintained some distance apart. Substation surge arrestors, fencing, and equipment frames are tied to the station ground bed, typically located under the substation area. The substation transformer is either delta-wye, delta-delta, or wye-delta connected (wye-wye is not recommended), and the secondary neutral (direct or derived) is tied to the safety ground bed through the neutral grounding resistor. Each ac equipment frame in the distribution system is connected via grounding conductors to the safety ground bed. The station ground bed is intended to handle lightning, other transformer primary surge conditions, and primary-system line-to-ground faults. The purpose of the safety bed is maintaining equipment frames at near earth potential, and a low bed resistance is important so dangerous potentials are not developed on machine frames.

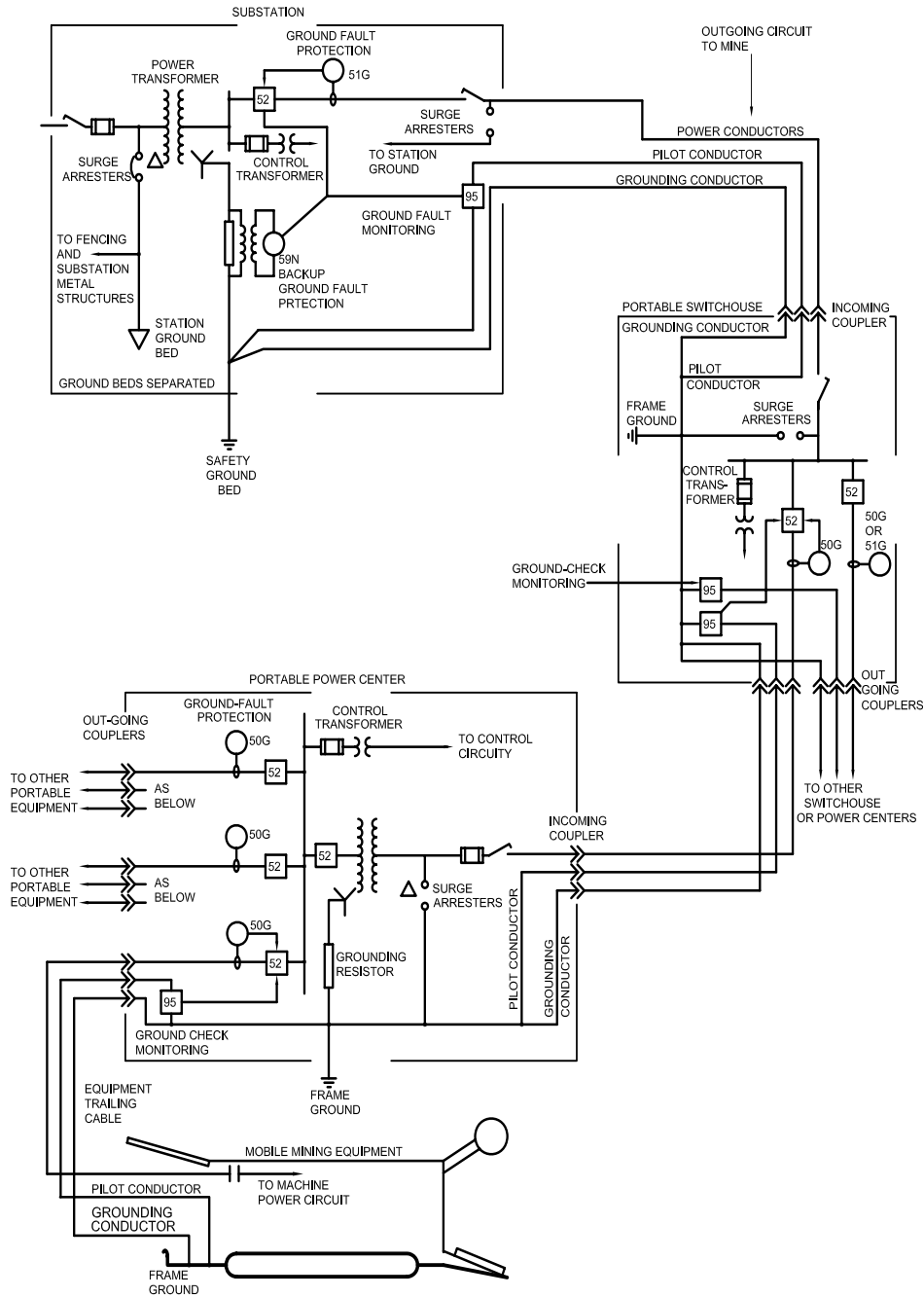

Figure 1-41—Simplified mine system with a safety grounded system (overcurrent and short-circuit schemes have been omitted)

Separation between the system and safety ground beds is needed to isolate high system-ground voltage rise (a temporary rise of 5 kV or more is not unusual) from the bed. This resistance is recommended as 5.0 ohm or less (see Lord; King). It is not unusual to find that a much greater distance is required to provide needed separation (see Cooley and King). The design of these ground beds is complex, and many variables must be examined to derive an optimum configuration (see Cooley; Cooley and King). The references cited in this paragraph should be consulted. IEEE Std 367 also contains important information about ground-bed separation in regard to the influence of a ground potential rise of a ground electrode.

At each transformation step within the distribution system, such as in a portable power center, an additional neutral point is established at the transformer secondary. The neutral is tied through a grounding resistor to the equipment frame and, thus, via the grounding conductors to the safety ground bed.

Because of the extensive use of cable distribution and the attendant capacitance from line-to-ground, ground-fault current limits are higher than that which was recommended for high-resistance grounding earlier in this chapter. U.S. practice specifies a different maximum current limit depending on the system voltage. When the system voltage is greater than 1000 V, ground current is limited so frame potentials within that system portion do not exceed 100 V during ground-fault conditions. For practical purposes (assuming a 2 ohm grounding conductor impedance), this restricts the maximum ground-current limit to not more than 50 A; however, most substations serving mines use a 25 A ground-current limit. For power system segments at or below 1000 V, the ground-current limit must be 25 A or less, but typical practice is 15 A. Distribution and utilization (mining) equipment in surface mines is typically greater than 1000 V. Underground mine distribution is almost always greater than 1000 V, whereas mining equipment is usually 1000 V or less.

Correct selection and coordination of protective circuitry are essential to the safety ground system. Regardless of where a ground fault occurs, ground-fault current is primarily limited by the grounding resistor, and selective coordination at each voltage level by the pickup setting alone is normally impossible. The common ground-fault relaying pickup is 40% of the ground-current limit, and time settings are relied on for multistage protection. Regulations should be consulted before selecting specific ground-fault protection schemes. (See Morley; Carson and Vidergar). A typical relaying arrangement is included in Figure 1-41 (see Morley).

Zero-sequence relaying (usually instantaneous) establishes primary ground-fault protection for the outgoing power conductors to the mine. Although not shown, backup protection may be employed (or required) at the portable power center by adding a time delayed zero-sequence relay to sense potential across the grounding resistor. For the distribution system, primary ground-fault protection in the switchhouse establishes a zone of protection for each outgoing circuit; again, zero-sequence relaying (instantaneous or minimum time dial setting) is typically used. Time delayed zero-sequence or residual relaying in the substation gives both backup protection for downstream relaying within the distribution safety ground. U.S. federal regulations specify separation by distance; for example, a minimum of 7.6 m (25 ft) and a "low resistance" for each system and primary

ground-fault protection for the zone between its location and the switchhouse. The potential relaying shown about the grounding resistor also provides backup protection (both relays are sometimes required in the substation). In order for the safety ground system to be effective, grounding conductors must be continuous, and ground-check monitors (relays) are used to verify continuity. Pilot conductors are shown with each monitor, but these are not needed in instances where pilotless relays are applied. All these sensors act to trip the associated circuit interrupter and remove all power to the affected system segment.

The correct operation of the safety ground system relies on three concepts, as follows:

- a) The earth cannot be used as a grounding conductor.
- b) The grounding system serving portable and mobile equipment must be kept isolated.
- c) Ground-fault protection must be provided on each outgoing circuit from the substation.

These criteria are sometimes difficult to achieve when other loads are being supplied from a mine substation transformer, such as preparation plants and ventilation fans. Regardless, each is particularly important when an underground mine is connected to the substation. To ensure grounding-system integrity, it is best that underground mine distribution be fed from a separate transformer secondary winding.

1.11 Creation of stray currents and potentials

If a current-carrying conductor, even though nominally at ground potential, is connected to earth at more than one location, part of the load current will flow through the earth because it is then in parallel with the grounded conductor. Since there is impedance in both the conductor and the earth, a voltage drop will occur both along the earth and the conductor. Most of the voltage drop in the earth will occur in the vicinity of the point of connection to earth, as explained in Chapter 4. Because of this nonlinear voltage drop in the earth, most of the earth will be at a different potential than the grounded conductor due to the load current flowing from this conductor to earth.

An EGC connected to the same electrode as the grounded load conductor will also have a potential difference from most of the earth due to the potential drop caused by the load current. In most instances the potential difference will be too low to present a shock hazard to persons or affect operation of conventional electrical load equipment. However, in many instances it has been of sufficient level to be detected by livestock, either by coming in contact with non-current-carrying enclosures to which an EGC is connected, or where sufficient difference in potential exists between the earth contacts of the different hoofs. Although potential levels may not be life threatening to the livestock, it has been reported that as little as 0.5 V rms can affect milk production (see Dick).

The NEC requires that the grounded circuit conductor (neutral) of a single system be connected to a different grounding electrode each time it enters a separate building when a separate EGC has not been installed with the phase conductors. In this case, where there is

a multi-building facility, as is common on farms, there will be some load currents flowing in the earth due to these multiple groundings.

If a separate EGC is run to each building and grounded, then any installed grounded circuit conductor shall not be connected to the EGC or to the grounding electrodes(s). Since no load current would be flowing into these grounding electrodes, the EGC should be at earth potential.

Another possible source of multigrounding of a neutral would be the use of the neutral for grounding of the frames of cooking ranges or clothes dryers, previously permitted in the NEC. If the appliance frame also has a separate connection to earth, the multigrounding of the neutral will be achieved. This practice should be avoided in the vicinity of the barns and even at other locations on farms.

There is another condition of multigrounding, since the utility will ground the neutral at the supply transformer and it must be grounded again at the service entrance. Since the EGC has its origin at the service entrance ground, it will have a potential to earth as a function of the voltage drop created by load current in the earth in parallel with the service drop neutral current. The magnitude of this potential will be affected by the size and length of the service drop neutral, the magnitude of the neutral current, and the resistance to earth of the service entrance grounding electrode as well as other connections to earth of the EGC. These factors are all subject to some control.

It is recommended that sources of stray currents on the premises that can be created by grounding of the neutral at other than the service entrance should be eliminated. Do not ground the neutral except at the service entrance. Make regular checks of electrical circuits and equipment to assure that unintentional grounding of either line or neutral has not occurred due to insulation failures. It is also recommended that voltages, caused by current in the service drop neutral, be minimized by balancing loads to minimize neutral current. All loads creating irregular currents, such as motors, should not be connected line-to-neutral.

There is a remaining source of circulating current when the utility distribution circuit includes a multigrounded neutral. The grounding of the supply-transformer secondary neutral has often been made common with the grounding of the primary neutral. It has been established that there may be a potential difference between this primary neutral and earth and that there may be primary load current flowing through the ground (see Stetson, Bodman, and Shull; Surbrook and Reese; Prothero, DeNardo, and Lukecart; Dick). This will be affected by the neutral current, the location on the distribution feeder, and the effectiveness of the various ground electrodes.

Neutral-to-ground voltages injected into the user system from the utility primary neutral cannot be eliminated by system grounding techniques on the premises, although some reduction may be achieved if the service entrance ground is made extremely effective and is located at some distance from livestock facilities. There are active systems to counteract equipment-to-ground voltages produced by utility injections (see Dick). Also, used are so-called equipotential ground planes, which bring earth surface voltages to the same value as

that of equipment (see Dick). Both of these are out of the scope of system grounding, but are mentioned for reader reference.

1.12 Avoiding common-mode noise

When all of the conductors of a signal or power system have an identical potential difference with respect to another reference, this potential is known as a *common-mode voltage* or *signal*. If such voltage or signal is undesirable, it is usually called *noise*. The other references are usually the equipment enclosure or the ground, both of which may be at the same potential. Electronic equipment may often exhibit a susceptibility to common-mode noise between the incoming power conductors and ground, which may affect either digital or analog signals.

Common-mode noise on a power source occurs when a potential difference exists between the ground to which the power source is referenced and the ground to which the power-consuming equipment is referenced. There is often a capacitive or resistive coupling between the equipment's circuitry and its enclosure. The potential difference can be created when there is a current flow in the EGC, or the earth, between the equipment enclosure and the power source grounding.

The earth has many stray currents, resulting in small potential differences between points. These currents may be other than power frequencies, and even if power frequencies, may contain transients or bursts due to switching or other aberrations. Therefore, if the equipment cabinet is connected to earth at its location, any potential occurring between there and the power system grounding point can be coupled into the circuitry.

The equipment enclosure can be maintained at the same potential as the power system ground if the EGC is of low impedance and has no connection to earth except at the grounding point of the source transformer, the so-called *single-point ground*. This is allowed by the NEC and is incorrectly referred to there as an isolated ground outlet or IG. The receptacle is supplied by an insulated EGC, and in IEEE Std 1100 (*IEEE Emerald Book*) it is referred to as an insulated grounding receptacle or IGR. The earth potential difference between the source grounding point and the equipment must not be sufficient to develop a shock hazard to persons standing within reach, and must not present the possibility of resistively or capacitively coupling this potential into the equipment enclosure at a magnitude sufficient to create a noise problem. Normally, meeting all these criteria is possible only if the equipment is physically and electrically close to the source transformer.

Connection of the equipment ground to earth with an electrode that is physically separate from all other power system and structural grounding electrodes and is not bonded to any of these other grounding electrodes, will inevitably produce common-mode noise, since it is not referenced to the power source ground. The magnitude of this common-mode potential can be destructive to the equipment and hazardous to personnel, since a power system fault can raise the power system or structure several hundred or thousand volts above other earth references. This grounding method is in violation of the NEC.

For greater detail on the grounding of equipment, refer to Chapter 5 of this standard and IEEE Std 1100 (*IEEE Emerald Book*).

1.13 Limiting transferred earth potentials

The term *transferred earth potentials* refers to the voltage to earth of grounding systems that will appear on conductors as a result of the source system grounding electrode being above normal earth potential. The larger voltages are usually developed by ground-fault currents returning to their source through earth. A common example is a ground fault of a conductor, which is supplying a substation transformer primary to the station ground grid that is used for grounding of the transformer secondary neutral. If this grounding grid is not connected to the high-voltage source system ground, there can be a significant voltage rise above earth as the fault current flows into the earth. Low-voltage conductors leaving the area where the ground or grounding electrode voltage has been affected will have that voltage added to their normal line-to-ground voltage. The total voltage may exceed the insulating rating of the conductors or the equipment to which they are connected.

Control and telephone circuits extend into areas where the grounding electrode or mat is subject to significant voltage rise are particularly vulnerable. High voltage appearing on such circuits is more likely to be a hazard to personnel and to exceed insulating ratings. Such conductors should not interconnect between two areas whose ground mat potential is not held equal unless special protection or isolation is applied to the low-voltage circuits. Another hazard can be created when portable or mobile equipment can be subjected to a transferred voltage rise. This is specifically treated in 1.11 as well as in the NEC.

Transferred potentials will be reduced if the resistance to earth or impedance between grounding grids is held to minimum. Isolation between low-voltage equipment at locations having unequal ground potentials can be accomplished by use of devices rejecting common-mode voltages (see IEEE Std 487TM). Such devices include isolation transformers, optical isolators, and similar devices to protect telecommunication cables going into high-voltage environment against transferred potentials (see Shipp and Nichols; IEEE Std 487).

Within most industrial distribution systems, compliance with the NEC requirements for EGCs and the running of the grounding conductor to the service entrance panel serve to limit such potentials to safe limits. If there are areas that are interconnected by three-wire overhead lines only, bonding provisions should be made before interconnecting low-voltage circuits between the two areas.

Low-voltage potential differences can be created by the flow of load or other small currents through ground or grounding conductors. These can be quite troublesome to livestock, as discussed in 1.12. It can also be troublesome to electronic equipment, particularly if the equipment is susceptible to common-mode voltages on the power supply conductors or common-mode voltages on communication lines that may run between locations with different earth potentials. Existing NEC grounding requirements designed to prevent the flow of load currents through grounding paths are often not adequate because of the vulnerability to their very low levels and because the voltages can

be caused by other phenomena. These problems are further discussed in Chapter 5 of this standard and in IEEE Std 1100 (*IEEE Emerald Book*). Further information is also available in Shipp and Nichols.

1.14 “Resonantly” produced voltages

This term is applied to the voltage that will appear at the junction between reactances of opposite sign connected in series even though the reactances may not actually be resonant at the supply frequency. The variance of the voltage with respect to the supply voltage will be a function of how close the elements are to resonance and the ratio (Q) of inductive reactance to the resistance.

A common instance is the use of series capacitors on low power factor loads where random switching or other variations create objectionable voltage excursions. Figure 1-42 represents the circuit of a spot welder whose inductance is fixed by the dimensions of the machine but whose resistive load can be varied. With full power factor correction, the voltage rise across the capacitor will be $1.732E$ at 0.5 power factor and $4.9E$ at 0.2 power factor. With the ground fault as shown, this $4.9E$ across the capacitor will be impressed between the source transformer and ground. Both the transformer and its grounding impedance will be subjected to overvoltage. For this reason, such series capacitors should be used only on effectively grounded systems, which will limit the voltage rise to safe values.

A more commonly observed series reactance circuit is created when a capacitive load is connected, usually for power factor and/or voltage correction. Since these capacitors are in series with the source reactance of the power system, the voltage is caused to rise. The voltage rise caused by the normal size of power factor capacitors would not be expected to exceed 5% to 10% under the worst conditions, since the system is not approaching resonance at the fundamental power frequency. This is not a different voltage class and does not present a hazard. Its discussion here is only to present a familiar example of reactances in series.

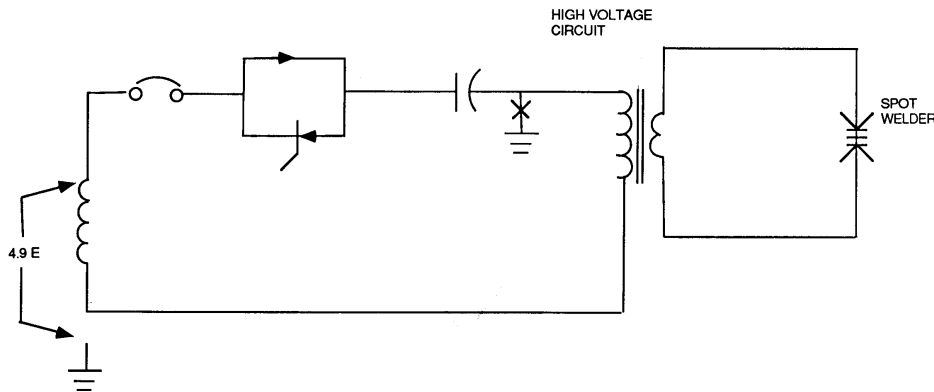

Figure 1-42—Series capacitor welder

Resonance can be achieved, at multiples of the power system frequency, by the addition of power factor capacitors. When there are sources of harmonics, such as nonlinear loads, the resulting harmonic voltages can be raised by a resonant condition. Such voltages would not normally reach hazardous values. A hazardous level, should it occur, would be rapidly reduced by overcurrents in the capacitors causing failures or fuse operations, thus detuning the circuit.

Impulse voltages can be amplified and extended as damped oscillations (ringing) by resonant circuits. These voltages can exceed insulation capabilities.

Resonant conditions prone to continuous oscillation due to lack of resistive loading (damping) can be triggered by switching or by system failures. The most common example is that created by single-phase switching of transformer primaries when there is no secondary load. This produces the *ferroresonant* condition where the excitation impedance of the transformer interacts with the capacitance of the primary cable.

These resonantly produced voltages are not considered useful system voltages, with the exception of the resistance welder application. Thus, they do not create multi-voltage systems, but are discussed here so that they might be avoided. With the exception of increasing the impulse capability of the insulation, the main defense against these voltages is suppression.

There are other situations where high voltages can be produced by inadvertently created resonant conditions. These are usually the result of insulation, equipment failures, or unintended circuit configurations. The voltages are more extreme if conditions at or close to resonance are achieved. When the inductive element has an iron core, the inductance can vary when the iron is saturated due to the high voltage, which at the same time causes nonsinusoidal current with resulting harmonics. This can result in arriving at a resonant condition referred to as *ferroresonance*. These are not “system voltages” as have been discussed in the preceding paragraphs, since they are unintended and may be transitory in nature.

In some cases, occurrence of these voltages can be affected or eliminated by the grounding design, but such changes in voltage also may involve choice of transformer design or performance of switching devices. A common cause of ferroresonance is the impressing of voltage across a transformer winding and a conductor capacitance to ground, the conductor having been disconnected from its normal source. If the transformer is wye connected, grounding of the neutral will usually prevent voltage being impressed across this series connection. A resonant condition produced by a grounded coil acting in series with the line-to-ground capacitance of an ungrounded system can be alleviated if the capacitance is shunted by grounding the system.

1.15 Grounding of dc power systems

1.15.1 General

Although there are some exceptions, the majority of dc power systems used in industrial and commercial applications today are limited size, special purpose systems. The grounding practices for these various systems are largely a function of the use of the particular system. Several varieties of systems and their usual grounding practices are described in this subclause.

1.15.2 NEC requirements

The NEC requires the grounding of two-wire dc systems feeding premises wiring, operating at greater than 50 V, but not greater than 300 V, with the following three exceptions:

- 1) A system equipped with a ground detector and supplying only industrial equipment in limited areas.
- 2) A rectifier-supplied dc system derived from an ac system complying with specific requirements.
- 3) DC fire alarm circuits having a maximum current of 0.030 A.

Note that many of the dc systems used in industrial and commercial installations are derived using rectifiers from properly grounded ac systems, and thus fall under Exception 2. Others may fall under Exception 1. Also, power systems for railways and mines are outside the scope of the NEC. However, nothing in the NEC prohibits grounding of these systems; as an option, they may be left ungrounded if one or more of the exceptions applies.

The NEC requires that the neutral conductor of all three-wire dc systems feeding premises wiring be grounded. No exceptions are permitted.

1.15.3 General purpose dc lighting and power systems

Although seldom found in recent construction, some general purpose dc lighting and power systems exist in industrial and commercial installations. Where these systems do exist, they should be solidly grounded in accordance with the NEC, as described in 1.15.2.

1.15.4 Station battery systems

Station battery systems are used as the control power source for switchgear and for process control instrumentation. In addition, the station battery may be used for emergency lighting and other emergency power requirements, such as bearing lube oil pumps for rotating machinery or valve actuators for critical valves. Station battery systems are operated ungrounded and usually have a ground detector. The ground detector may be lamps, voltmeter(s), or alarm relay(s). The ground detector is frequently furnished as an optional part of the battery charger.

1.15.5 Electrochemical systems

Electrochemical cell lines are used for the separation of chemicals or metals from raw materials or from materials produced as an intermediate step in the process. Additionally, electrochemical cell lines may be used to provide corrosion and abrasive resistance or to change surface appearance. Typical uses are the production of chlorine and sodium chlorate, and the refining of aluminum, magnesium, and copper. In general, the cells are connected in series-parallel configurations and are supplied from rectifiers or dc generators. Voltages may be as high as 1200 V and currents as high as 400 kA. Higher currents are found in the chlorine industry and higher voltages in the aluminum industry.

Electrochemical lines are generally operated ungrounded. Line-to-ground voltages are monitored so that grounds may be detected and removed before a second ground occurs. Some higher voltage dc pot lines in aluminum smelters may be grounded through a fuse, which is monitored. The fuse blows on the first occurrence of a ground fault, and an alarm is sounded.

Operators and maintenance personnel ordinarily work on electrochemical systems while the system is energized. Safety information may be found in IEEE Std 463TM-2006 [B10].

1.15.6 UPS systems dc link

Refer to 1.9 for information on grounding of UPS systems, including the dc link.

1.15.7 Solar photovoltaic systems

The NEC addresses the grounding of solar photovoltaic systems. For a photovoltaic power source, the NEC requires that one conductor of a two-wire dc system over 50 V and the neutral conductor of three-wire dc systems be grounded. An exception states, "Other methods that accomplish equivalent system protection and that utilize equipment listed and identified for the use shall be permitted." The NEC states that the direct-current circuit grounding connection shall be made at any single point on the photovoltaic output circuit.

1.15.8 Mining power systems

Refer to 1.10 for information on grounding of mining power systems, including the dc portion of those systems.

1.15.9 Transit power systems

Transit power systems are a special class of dc power systems. Special consideration must be given to both system and equipment grounding. The method of grounding has a significant impact on personnel safety and equipment performance. Problems associated with grounding can include hazards to the general public, hazards to operating and maintenance personnel, communication system interference, corrosion of steel, and shortened equipment life. As transit systems by their nature interface with the general public, it is essential that special care be given to the methods of grounding these systems.

Transit systems vary by type of system and location or access to the right-of-way. In choosing a grounding system, the designer must be cognizant of these differences.

Due to the power requirements, the vast majority of heavy rail transit systems are *third rail* systems. The third rail is usually at a positive dc voltage with respect to the running rails. The running rails are used for the negative return to the substations. Typically, the running rails are not intentionally grounded to reduce stray ground current.

Light rail and streetcar systems usually operate with a positive overhead trolley wire and use the running rails as a negative return.

Typically, people mover systems and certain light rail systems use vehicles with rubber wheels. These systems use two power rails and usually operate with a resistive ground detection system.

Electric bus systems use double overhead conductors and usually use a resistive ground detection system similar to isolated power rail systems.

Traction power systems are further classified by the access to the right of way they use. This is an important factor in designing the system grounding because it will determine whether the general public has access to the tracks, and it will dictate the need for special stray current control such as in a steel tunnel liner.

Underground systems are either bored or constructed using the cut and cover method. In either case, the final result is usually a tunnel of reinforced concrete. In some under-river systems a steel tube is also used. The electric system designer and track support designer must be cognizant of the construction type and understand the current paths and their possibly corrosive effects.

Surface systems are further divided by the type of highway crossings used. If the system has road crossings that are at grade level, then the same precautions that apply to street running systems must be taken, as the general public will have access to the running rails. All systems with grade crossings must use overhead power conductors.

Elevated systems present a different challenge to the system designer. With a massive steel structure in place, the stray current paths must be considered so corrosion will be minimized.

Street running systems must be designed with step and touch potentials of the running tracks given special attention.

Fixed guideway is another form of dedicated right-of-way but is usually a cast concrete structure of some type.

Isolated or ungrounded traction systems have no intentional ground reference. *Intentional* is the operative word in this sentence. Several miles of track laid on ground does create a reference of usually low impedance to ground. There are several methods of laying the

running rails. The electric system designer should be aware of this and the effect of ground currents and of step and touch potentials in an isolated ground system.

Grounded rail systems have an intentional ground reference established, usually by the ground grids at the substations. These systems can then bond structures along the right-of-way to the rail system to reduce the step and touch potentials. This method of grounding is usually only applicable to light duty streetcar systems with no railroad signaling that requires an isolated running rail system.

Some systems operate normally as ungrounded systems, with the running rails monitored by ground rise monitors in passenger stations and other areas accessible to the public. If the running rail rises to a certain voltage relative to the surrounding grounded structures a grounding contactor will close temporarily, connecting the running rails to the structure grounding system.

1.15.10 Stray currents in transit power systems

While dc current theory is generally considered rather simple, the dynamics of traction power systems create some significant problems. These systems are characterized by the following:

- a) High load current (1 kA to 10 kA)
- b) Moving loads
- c) Large land areas
- d) A negative return conductor embedded in the earth.

These features all contribute to stray currents, which are defined as currents returning to the source by any path other than the intended conductor. These other paths may be the following:

- 1) The earth
- 2) Nearby power lines
- 3) Utility lines in parallel with the system
- 4) Steel building structures
- 5) Pipelines

The amount of stray current is dependent on the impedance of the return paths. These impedances are determined by the following:

- Track construction
- Soil conditions
- The arrangement and construction of nearby pipelines, buildings, utility power lines, and other man-made structures
- Bonding between rail sections

Stray currents cause problems in various ways. These include the following:

- Electrolysis of building steel and pipes

- Overheating of utility lines
- Running rail corrosion
- Interference with communication systems

Mitigation of stray current is best done in the initial design of the traction power system. The primary mitigation method is to construct the track system with low impedance and isolated from other ground reference. The problem with this is that the better the isolation, reducing the stray currents, the higher the risk of dangerous step and touch potentials. Most systems today are built with welded steel rails that provide good bonding and low impedance. The transit cars are referenced to the same potential as the rails. This requires some thought to be put into passenger station design to eliminate hard grounds such as guardrails or floor grates on the station platforms. It is important to isolate the utility ground system from the running rails. This can sometimes be a problem because many transit systems are built on multiple use rights-of-way that include a utility line. The placement of utility grounds from surge arresters and transformer neutrals is important. If the utility is using transformers with solidly grounded primaries, significant amounts of current can travel through the transformer windings to the phase conductors and to the next transformer. Since this is a dc current, it can cause saturation of the transformers and serious damage due to overheating. Line overheating may also be a problem, due to the excessive current.

Stray current in structures does not necessarily cause problems. The problem areas are usually the entrance and exit points. As the current passes from the steel structure to the earth, electrolysis can occur, causing significant corrosion of metal. This can be mitigated by connecting bonding (drainage) cables to the steel members. The drainage cables are connected to the negative bus in the substation and each drainage circuit should include a diode to prevent reverse current flow.

1.15.11 DC surge arresters

Surge arresters are used in dc transit systems for the same reason surge arresters are used in ac systems—to clamp a voltage rise at a level the equipment can withstand and to dissipate the energy in the voltage peak.

Care and planning are required in the selection of the location of dc arresters. Considerations are the following:

- a) Length of leads
- b) Proximity to protected equipment
- c) Isolation from ac ground grids, especially if the ac primary is not solidly grounded
- d) Isolation of ground leads from ungrounded structure

1.16 Normative references

The following referenced documents are indispensable for the application of this document (i.e., they must be understood and used, so each referenced document is cited in the text and its relationship to this document is explained). For dated references, only the

edition cited applies. For undated references, the latest edition of the referenced document (including any amendments or corrigenda) applies.

Baker, D. S., "Charging Current Data for Guesswork-Free Design of High Resistance Grounded Systems," *IEEE Transactions on Industry Applications*, vol. IA-15, no. 2, pp. 136–140, March/April 1979.

Beeman, D. L., Ed., *Industrial Power Systems Handbook*. New York: McGraw-Hill, 1955.

Carson, D. B., and Vidergar, J. A., "Considerations of Ground Fault Protection as Influenced by the Occupational Safety and Health Act and the Mining Enforcement and Safety Administration," *IEEE Transactions on Industry Applications*, vol. IA-11, no. 67, p. 108, November/December 1975.

Clark, H. H., and Means, C. M., "Suggested Safety Rules for Installing and Using Electrical Equipment in Bituminous Coal Mines," T. P. 138, U.S. Bureau of Mines, Washington, DC, 1916.

Cooley, W. H., and Hill, H. W., Jr., "Coupling of Mine Grounds to Surface Grounds," *IEEE Transactions on Industry Applications*, vol. IA-22, no 2, March/April 1986, p. 360.

Cooley, W. L., "Design Considerations Regarding Separation of Mine Safety Ground and Substation Ground Systems," *IEEE IAS Conference Record*, Annual Meeting, October 1977.

Cooley, W. L., and King, R. L., "Guide to Substation Grounding and Bonding in Mine Power Systems," IC8835, 1980.

Dick, W. K., and Winter, D. F., "Computation, Measurement and Mitigation of Neutral-to-Earth Potentials on Electrical Distribution Systems," *IEEE Transactions on Power Delivery*, vol. PWRD-2, no. 2, April 1987.

Electrical Transmission and Distribution Reference Book, 4th Edition, Westinghouse Electric Corp., Chapters 2 and 6.

Foster J. W., Brown W. O., and Pryor, L. A., "High Resistance Grounding in the Cement Industry—A User's Experience," *IEEE Transactions On Industrial Applications*, vol. IA-22, no. 2, March/April 1986, pp. 304–309.

IEEE Std 367, IEEE Recommended Practice for Determining the Electric Power Station Ground Potential Rise and Induced Voltage from a Power Fault.^{4, 5}

⁴IEEE publications are available from the Institute of Electrical and Electronics Engineers, 445 Hoes Lane, P.O. Box 1331, Piscataway, NJ 08855-1331, USA (<http://standards.ieee.org/>).

⁵The IEEE standards or products referred to in this clause are trademarks of the Institute of Electrical and Electronics Engineers, Inc.

IEEE Std 399, IEEE Recommended Practice for Power System Analysis (*IEEE Brown Book*).

IEEE Std 446, IEEE Recommended Practice for Emergency and Standby Power Systems for Industrial and Commercial Applications (*IEEE Orange Book*).

IEEE Std 487, IEEE Recommended Practice for the Protection of Wireline Communication Facilities Serving Electric Supply Locations.

IEEE Std 1100, IEEE Recommended Practice for Powering and Grounding Electronic (*IEEE Emerald Book*).

IEEE Std C37.101, IEEE Guide for Generator Ground Protection.

King, R. L., et al., *Guide for Construction of Driven-Rod Ground Beds*, IC8767. Washington, DC: U.S. Bureau of Mines, 1978.

Lordi, A. C. "How to Safely Ground Mine Power Systems," *Coal Age*, vol. 68, no. 9, September 1963, pp. 110–117.

McFadden R. H., "Grounding of Generators Connected to Industrial Plant Distribution Buses," *IEEE Transactions On Industry Applications*, vol. IA-17, no. 6, November/December 1981, pp. 553–556.

Morley, L. A., *Mine Power Systems*, IC9258. Washington, DC: U.S. Bureau of Mines, 1990.

NEMA MG 1 1993, Motors and Generators, Part 22.⁶

NFPA 70, National Electrical Code® (NEC®).⁷

Nichols, N., "The Electrical Considerations in Cogeneration," *IEEE Transactions on Industry Applications*, vol. 1A-21, no. 3, May/June 1985.

Pillai et al., "Grounding and Ground Fault Protection of Multiple Generator Installations on Medium-Voltage Industrial and Commercial Power Systems—Part 1: The Problem Defined; Part 2: Grounding Methods; Part 3: Protection Methods; Part 4 Conclusion and Bibliography," Working Group Reports, *IEEE Transactions on Industry Applications*, vol. 40, no. 1, January/February 2004, pp. 11–32.

Prothero, J. N., DeNardo, C. M., and Lukehart, B. W., "Primary Neutral-to-Earth Voltage Levels as Affected by System Grounding, Neutral Separation and Load Balancing," *IEEE IAS Conference Record*, October 1989.

⁶NEMA publications are available from Global Engineering Documents, 15 Inverness Way East, Englewood, Colorado 80112, USA (<http://global.ihs.com/>).

⁷NFPA publications are available from Publications Sales, National Fire Protection Association, 1 Batterymarch Park, P.O. Box 9101, Quincy, MA 02269-9101, USA (<http://www.nfpa.org/>).

Shipp, D. D., and Nichols, N., "Designing to Avoid Hazardous Transferred Earth Potentials," *IEEE Transactions on Industry Applications*, vol. IA-18, no. 4, July/August 1982.

Stetson, L. E., Bodman, G. R., and Shull, H., "An Analog Model of Neutral-to-Earth Voltages in a Single-phase Distribution System," *IEEE Transactions on Industry Applications*, vol. IA-20, no. 2, March/April 1984.

Surbrook, T. C., and Reese, N. D., "Trouble Shooting Earth to Neutral Voltage," *IEEE IAS Conference Record*, October 1989.

"System Grounding for Uninterruptible Power Systems," Liebert Corporation, Publication No. PLT-41, October 1986.

Woodbury F. A., "Grounding Considerations in Cogeneration," *IEEE Transactions On Industry Applications*, vol. IA-21, no. 6, November/December 1985, pp. 1523–1532.

1.17 Bibliography

[B1] AIEE Committee Report, "Recommended Grounding Practices for Single Polarity DC Structures," October 1957, pp. 784–790.

[B2] Bridger, B., Jr., "High Resistance Grounding," *IEEE Transactions on Industry Applications*, vol. IA-19, no. 1, January/February 1983, pp. 15–21.

[B3] Castenschild, R., "Grounding of Alternate Power Sources," IEEE Conference Record 77 CHG 1246-B-IA, October 1977, pp. 92–99.

[B4] Eisele, H., "Grounding in DC Traction Substations," *American Public Transportation Association Rapid (APTA) Transit Conference*, 1982.

[B5] Forquer, P. F., "Equipment Grounding in DC Traction Substations," *American Public Transportation Association Rapid (APTA) Transit Conference*, 1993.

[B6] Gustafson, R. J., and Albertson, V. D., "Neutral-to-Earth Voltage and Ground Current Effects in Livestock Facilities," *IEEE Transactions on Power Apparatus and Systems*, vol. PAS-10, no. 7, July 1982, p. 2090.

[B7] Hoffman, D. C., "Grounding of DC Structures and Enclosures," *AIEE Winter General Meeting*, New York, NY, 1961.

[B8] IEEE 100, *The Authoritative Dictionary of IEEE Standards Terms*, Seventh Edition. New York: Institute of Electrical and Electronics Engineers.

[B9] IEEE Std 242™-2001, IEEE Recommended Practice for Protection and Coordination of Industrial and Commercial Power Systems (*IEEE Buff Book™*).

[B10] IEEE Std 463TM-2006, IEEE Standard for Electrical Safety Practices in Electrolytic Cell Line Working Zones.

[B11] Kaufmann, R. H., and Page, J. C., "Arcing Fault Protection for Low-Voltage Power Distribution Systems," *AIEE Transactions on Power Apparatus and Systems*, vol. 79, June 1960, pp. 160-167.

[B12] Rowe, E., "Compact Substations for Trolley Bus and Light Rail Transit Applications," *American Public Transportation Association Rapid (APTA) Transit Conference*, 1992.

[B13] Surbrook, T. R., Reese, N. D., and Althouse, J. R., "Parameters Affecting Neutral-to-Earth Voltage Along Primary Distribution Circuits," *IEEE Transactions on Industry Applications*, vol. 24, no. 5, September/October 1988.

[B14] Wagner, C. L., "Effect of Grounding Impedance on the Magnitude of Transient Overvoltage Due to Arcing Grounds," *Electric Utility Engineering Report*, no. 60-166, Westinghouse Electric Corp., June 14, 1960.

[B15] Wagner, C. L., Ferguson, W. H., and Nordman, D. A., "High Resistance Grounding for Unit-Connected Generators," *Electric Utility Engineering Report*, no. 59-58, Westinghouse Electric Corp., February 27, 1959.

[B16] Zipse, D. W., "Multiple Neutral-to-Ground Connections," *IEEE I&CPS Technical Conference*, May 1972, pp. 60-64.